

PITT
COOKING



from the heart of

Holland

Meet PITT cooking: gas burners arranged your way on your countertop.

The pursuit of culinary perfection. Let creativity in the kitchen soar! A powerful flame for effortless cooking. Finally enough space for all your pots and pans. Your kitchen. Your showplace.

A perfect marriage of function and design.
Made in Holland.

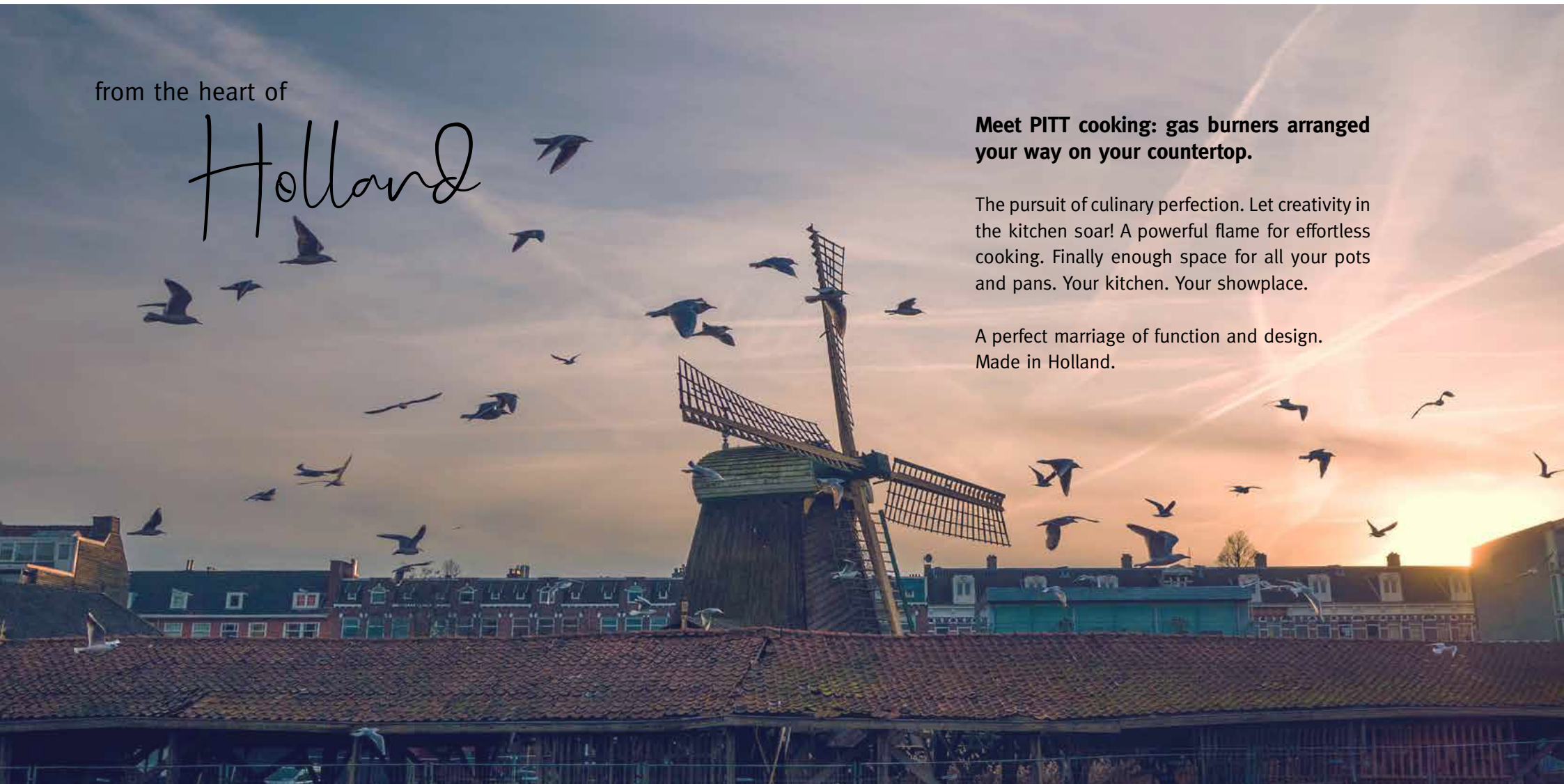



made by hand

Every PITT cooking burner system is carefully made by hand in de Meern, a small village close to Amsterdam. Office, production facility and showroom are all together under one roof. The PITT cooking team is one family. A team dedicated to providing the finest quality products and service.



Project from Italy



Index

Product information

MEET PITT COOKING

- **What is PITT cooking?** 12
- **Why choose PITT cooking?** 22

ABOUT THE PITT COOKING SYSTEM

- **The burners**
 - The different types of burners 39
 - Simmer-/stir fry burner 40
 - Selection of material Original, Professional & Black 42
- **Control knobs**
 - Control knobs: Top Side 46
 - Control knobs: Front Side 48
- **Accessories**
 - Wok ring 52
- **Homeware**
 - PITT Pan 55

ASSORTMENT

- **PITT cooking assortment**
 - Select your favorite model 64
 - Overview of assortment 65
- Inspiration 70
- Contact 72
- Sources 74
- Online 75

Throughout the entire book you will find a number of QR-codes. These provide links to excellent videos, additional information or a website. With an iPhone you can simply scan these with the camera. For other cell phones, you can download a QR-scanner in the App-store.



Technical information

- **Assortment**
 - Technical information by model 78
- **The PITT cooking system**
 - The module 122
 - The burners 124
 - Burner functionality 126
 - Simmer-/stir fry burner 128
 - Wok ring 129
 - Operation 130
- **Preparation**
 - Requirements for countertop 132
 - Gas & Electric 133
 - Construction measurements 134
 - Cut-outs 139
 - Construction checklist 141
- **Installation**
 - Requirements 143
 - Installation instructions: Top Side 144
 - Installation instructions: Front Side 147
 - Support bar package 150
 - Changing gas nozzles 151
- Certifications 153
- How to order 154
- Conditions and warranty 155
- Contact 156
- Documentation 157



Model: Drum, Black Edition

What is PITT cooking?

Powerful gas burners directly installed onto your countertop.

- An integrated (gas) cooking system.
- Robust cast iron grates
- A range of burners: from simmer to stir fry, low flame to high flame
- Plenty of space between burners
- Suitable for your favorite countertop material
- Safe and certified
- Made by hand in the Netherlands

PITT cooking is a cooking system whereby gas burners are installed directly into the countertop.

Thanks to generous space between burners you will now have enough space for all your pots and pans. With a wide assortment of 20 different models there is something to suit everyone. Or you can combine different configurations to customize your ideal cooking setup.

PITT cooking has earned KIWA GASTEC certification and is therefore safe to install into virtually any countertop.





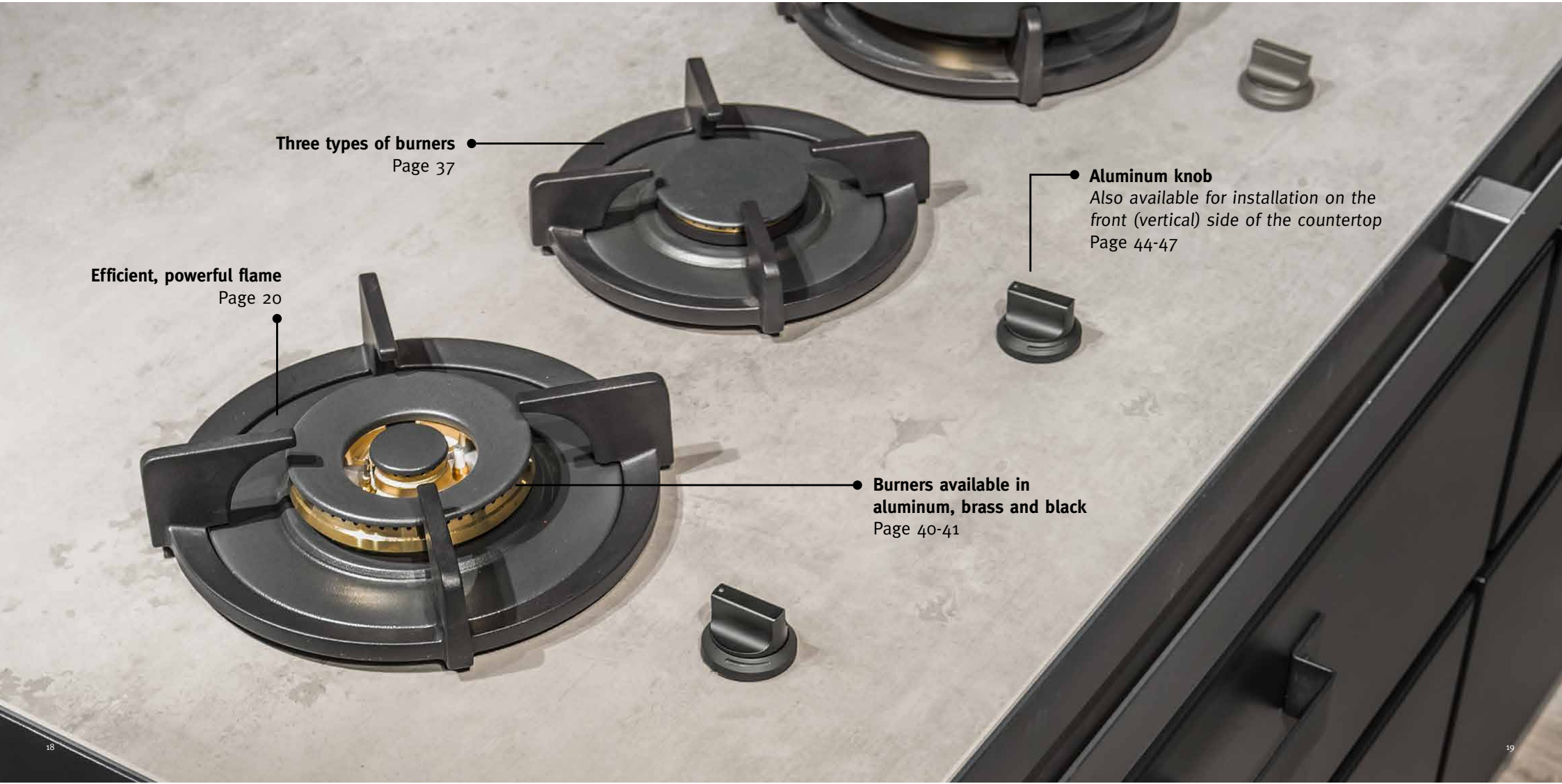

• **Three types of burners**
Page 37

• **Efficient, powerful flame**
Page 20

• **Aluminum knob**
Also available for installation on the front (vertical) side of the countertop
Page 44-47

• **Burners available in aluminum, brass and black**
Page 40-41



Why choose PITT cooking?

Flame control.

Back to the beginning of time, cooking with fire. Real cooking the way it was always meant to be. The pure joy of culinary creativity!

You will have infinite control over the flame. Air flow from above provides for superior burner performance: a responsive, powerful and efficient flame.





Why choose PITT cooking?

A masterpiece in the kitchen.

Thanks to its timeless look, PITT cooking looks great in any type of kitchen: from classic to country, from contemporary to designer. The black cast iron grates will complement your kitchen decor. And make your kitchen that much more striking.



Model: Capital, Original Edition

Why choose PITT cooking?

Plenty of space for all your cookware.

Finally enough space for all your pots and pans: with a minimum of 28 centimeters between burners PITT cooking provides an average of 8 centimeters more space between burners when compared with a traditional cooktop.

From now on, you will always have enough room to use all burners at once, even with several large diameter pans.



Model: Capital, Professional Edition

Why choose PITT cooking?

Quality and safety.

PITT cooking has been granted KIWA GASTEC QA certification. This certification offers users certainty that their (gas) product complies with stringent requirements for quality, function and safety.

PITT cooking offers a full five year guarantee on the gas cooking system.

Why choose PITT cooking?

Easy to clean.

Never again dread cleaning up the stove. Since there are no edges and crannies there is only a smooth countertop to clean. So PITT cooking provides easy cooking as well as easy clean up!



▶ Ease of cleaning



Floating grates
The four "arms" offer any size pan a stable surface on which to rest. Made of the highest quality double enameled cast iron.

Heat shield
Diffuses heat. Also serves as a catch tray.

Burner components
Available in aluminum, brass (photo) and black.

Silicone ring
Hermetically seals out moisture and dirt.

The burners

From simmer to stir fry.



● **Small burner**

Minimum output: 1,024 BTU
Maximum output: 6,142 BTU
Circumference: 9 1/16 In.
Automatic ignition: ✓
Flame protection: ✓



● **Medium burner**

Minimum output: 1,024 BTU
Maximum output: 10,236 BTU
Circumference: 9 1/16 In.
Automatic ignition: ✓
Flame protection: ✓



● **Combined simmer/stir fry burner**

Minimum output: 682 BTU
Maximum output: 17,061 BTU
Circumference: 10 5/8 In.
Automatic ignition: ✓
Flame protection: ✓

The burners

Stir fry or simmer: one burner, one knob.

The combined simmer/stir fry burner is unique: high flame stir frying as well as simmering functions in a single burner. Use only the inner small ring to simmer or both rings to cook over a high flame. Both rings are controlled by the same knob.

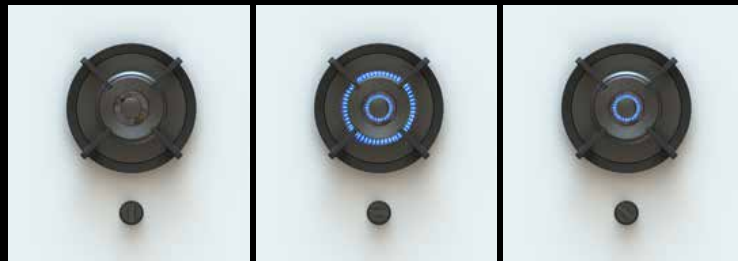

Burner off

Knob at half open position:
high flame

Knob at full open position:
low flame



The burners

Select your favorite material.



Professional Edition

Burners of heavy brass. For those who wish to cook in style.



Black Edition

Black enameled brass burners. Handsome and refined.



Control knobs

Top Side

● PITT cooking models with Top Side controls have the control knobs installed on the surface of the countertop.

- Aluminum knob
- Minimalist design
- Soft touch surface
- Silky feel



Control knobs

Front Side

- PITT cooking models with Front Side controls have the knobs installed on the vertical front side of the countertop itself or on the cabinet panel.
 - Aluminum knob
 - More space on the countertop
 - Ergonomic design: optimized, enhanced grip

Accessories

Stir frying the way it's really meant to be.

The PITT wok ring provides ideal stir fry effectiveness. Inspired by Chinese wok technique, its three “arms” maintain the stability of the wok at all times during use. The precisely calculated height and rounding of the ring assure superior flame distribution that heats the wok just right. Efficient and powerful cooking at high heat.

The wok ring is designed specifically for use on the combined simmer/stir fry burner.







Model: Capital, Professional Edition





Model: Colo, Professional Edition



Select your ideal configuration.

PITT cooking offers an assortment of 20 different configurations. All of these can also be combined with one another. Your ideal custom cooking setup to suit your personal cooking style and the space available in your kitchen.

How do I select the right model?

Step 1: Decide on the number of burners desired

Thanks to the generous space available between burners, you can use them all at once at any time.

Step 2: Choose your ideal configuration (or combine)

Models are composed of three different burner sizes: small, medium and simmer/stir fry.

Step 3: Select your favorite burner material

- Original (aluminum burners)
- Professional (brass burners)
- Black (black burners)

Step 4: Select the position of the control knobs

- Top Side (on the countertop)
- Front Side (on the vertical front of countertop or cabinet panel)

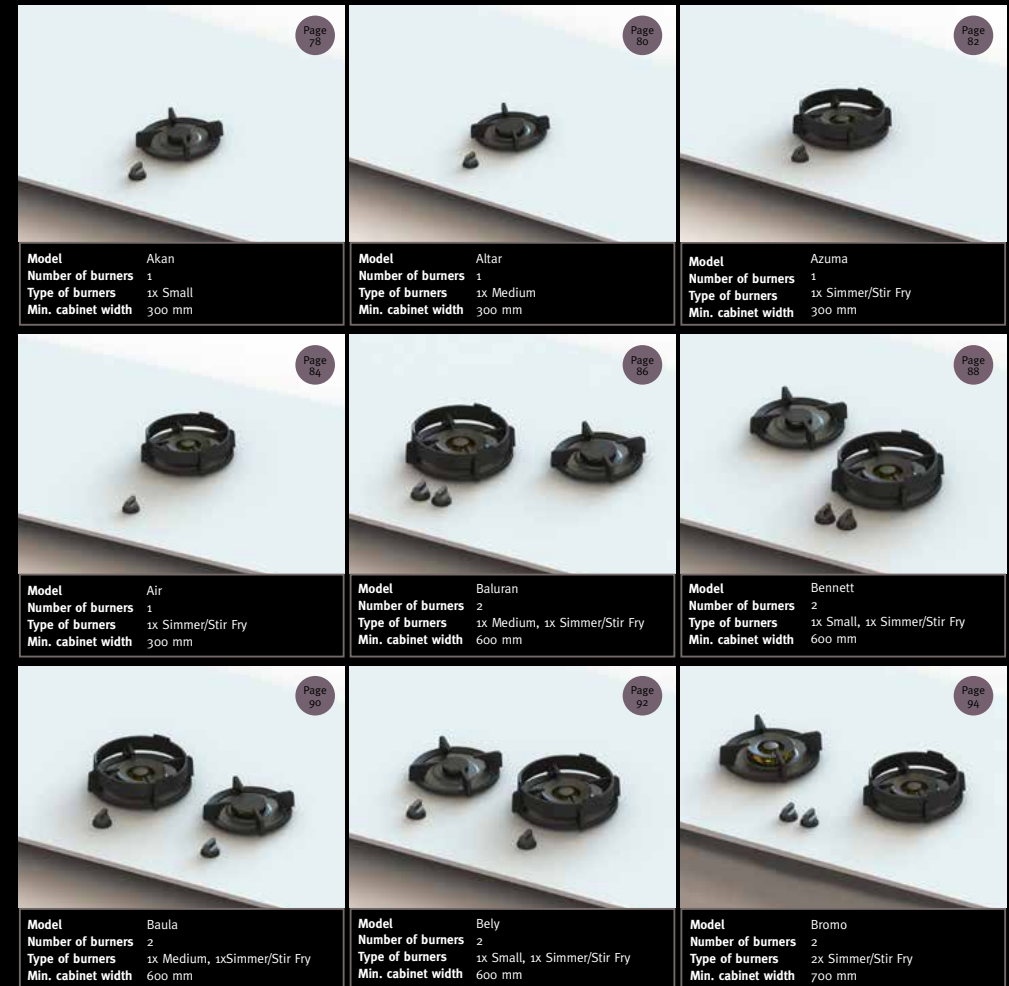



Page 113

Only available with Front Side knobs

Model Bandai
Number of burners 2
Type of burners 1x Small, 1x Medium
Min. cabinet width 500 mm



Page 96

Model Cima
Number of burners 3
Type of burners 1x Small, 1x Medium, 1x Simmer/Stir Fry
Min. cabinet width 600 mm



Page 98

Model Capital
Number of burners 3
Type of burners 1x Small, 1x Medium, 1x Simmer/Stir Fry
Min. cabinet width 600 mm



Page 108

Model Dempo
Number of burners 4
Type of burners 1x Small, 1x Medium, 2x Simmer/Stir Fry
Min. cabinet width 900 mm



Page 110

Model Elbrus
Number of burners 5
Type of burners 2x Small, 2x Medium, 1x Simmer/Stir Fry
Min. cabinet width 900 mm



Page 100

Model Cusin
Number of burners 3
Type of burners 1x Medium, 2x Simmer/Stir Fry
Min. cabinet width 900 mm



Page 102

Model Colo
Number of burners 3
Type of burners 1x Small, 2x Simmer/Stir Fry
Min. cabinet width 900 mm



Page 112

Model Enep
Number of burners 5
Type of burners 2x Small, 2x Medium, 1x Simmer/Stir Fry
Min. cabinet width 900 mm



Page 114

Model Ebeko
Number of burners 5
Type of burners 2x Small, 2x Medium, 1x Simmer/Stir Fry
Min. cabinet width 900 mm



Page 104

Model Danau
Number of burners 4
Type of burners 1x Small, 1x Medium, 2x Simmer/Stir Fry
Min. cabinet width 1200 mm



Page 106

Model Drum
Number of burners 4
Type of burners 1x Small, 1x Medium, 2x Simmer/Stir Fry
Min. cabinet width 1200 mm



Page 116

Model Foessa
Number of burners 6
Type of burners 2x Small, 2x Medium, 2x Simmer/Stir Fry
Min. cabinet width 1200 mm

Please note:

- All models are available in Original, Professional or Black and with Top Side or Front Side knobs.
- All models can be combined with one another.
- Each model with a Simmer/Stir Fry burner is provided with a separate wok ring.

PITT cooking Assortment







Inspiration



The stuff that dreams are made of.

We at PITT cooking take great pride in being a part of the dream.



On PITT cooking social media channels you will find beautiful examples have been shared of installations completed with pride.

Get inspired!

-  [instagram.com/pittcooking](https://www.instagram.com/pittcooking)
-  [facebook.com/pittcooking](https://www.facebook.com/pittcooking)
-  [pinterest.com/pittcooking](https://www.pinterest.com/pittcooking)





Contact

For questions or advice.

Do you have questions or need information that has not been addressed in this material? Feel free to contact us. We're here to help!

- ✉ info@pittcooking.com
- ☎ +31 (0)88 088 70 70
- 🌐 www.pittcooking.com



- 📍 **PITT cooking**
Damzigt 54
3454 PS De Meern
The Netherlands

Sources

Page	Reference
Cover	Krautkopf
8	Manola van Leeuwe/Fotografie Plus
14-15	Spekken Interieur
16-17	Fred Constant
18-19	Kitchen Concepts
20-21	Chef's Line
24-25	<i>From left to right:</i> Fred Constant, LOFT Interieurs - Wave Design in collaboration with Manola van Leeuwe/Fotografie Plus, Houtmerk, Vipp, Sense Keukens, Lume, Krautkopf, Kitchen Concepts, Vipp, NOMAA, Kolenik, Cesar
26-27	Florense F53
32-33	Dutch Kitchen Design
36-37	JP Walker
40-41	Krautkopf
44-45	The Living Kitchen by Paul van de Kooi
50-51	The Living Kitchen by Paul van de Kooi
60-61	Krautkopf
62-63	Koak Design
68-69	Piet Boon
70-71	<i>From left to right:</i> Koak Design, Cesar, Moervast/YellowEyes, Dada, Culimaat, Molitli, Florense 53, Van den Kommer, Van den Kommer, Boffi, Van Os, Fred Constant, Jacob Interior, Fendi, i29 interior architects, Dirk Coussaert
76-77	The Living Kitchen by Paul van de Kooi

All remaining images are the property of PITT cooking Netherlands and photography is by Victor van Leeuwen of LevendEcht.

Online resources

— About PITT cooking



— Product



— Assortment



— Inspiration/projects



— Social media



Contents

Technical information

— Assortment		
1 burner	Akan	78
1 burner	Altar	80
1 burner	Azuma	82
1 burner	Air	84
2 burners	Baluran	86
2 burners	Bennett	88
2 burners	Baula	90
2 burners	Bely	92
2 burners	Bromo	94
3 burners	Cima	96
3 burners	Capital	98
3 burners	Cusin	100
3 burners	Colo	102
4 burners	Danau	104
4 burners	Drum	106
4 burners	Dempo	108
5 burners	Elbrus	110
5 burners	Enep	112
5 burners	Ebeko	114
6 burners	Foessa	116
2 burners	Bandai	118
Accessories	Wok ring	119
Accessories	Support bar	119
Homeware	PITT Pan	119
— About the system		
	The module	122
	The burners	124
	Functioning of the burners	126
	Simmer/Stir Fry burner	128
	Wok ring	129
	Knobs: position	130
	Knobs: dimensions	131
— Preparation		
	Countertop requirements	132
	Gas & Electric	133
	Construction measurements	
	Top Side	134
	Front Side	136
	Cutouts	139
	Construction checklist	141
— Installation		
	Requirements	143
	Installation instructions	
	Top Side	144
	Front Side	147
	Support bars	150
	Changing orifices	151
	Certifications	153
	How to order	154
	General conditions and guarantee	155
	Contact information	156
	Downloads	157



Model name	Akan (Top Side)
Output	6,124 BTU
Measurements of unit	L: 503 W: 213 H: 89 mm
Total height	119 mm (incl. supports)
Min. cabinet width	300 mm
Min. counter depth	600 mm
Countertop thickness	4 - 35 mm
Gas	Natural Gas / LPG (Propane)
Burner material	Original
	Professional
	Black

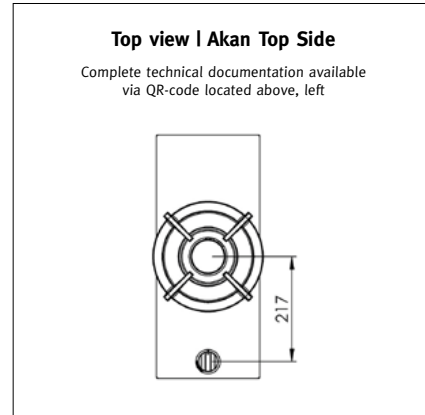

Model name	Akan (Front Side)
Output	6,124 BTU
Measurements of unit	L: 503 W: 213 H: 134 mm
Total height	164 mm (incl. supports)
Min. cabinet width	300 mm
Min. counter depth	650 mm
Countertop thickness	4 - 25 mm
Gas	Natural Gas / LPG (Propane)
Burner material	Original
	Professional
	Black

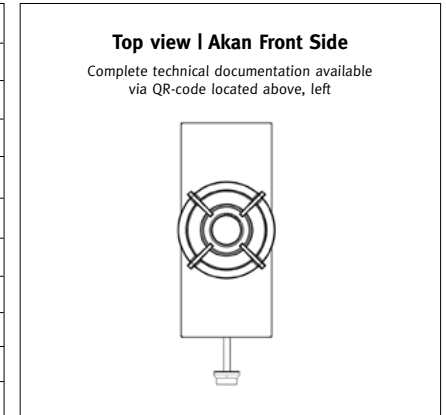



Altar Top Side

Model name	Altar (Top Side)
Output	10,236 BTU
Measurements of unit	L: 503 W: 213 H: 89 mm
Total height	119 mm (incl. supports)
Min. cabinet width	300 mm
Min. counter thickness	600 mm
Countertop thickness	4 - 35 mm
Gas	Natural Gas / LPG (Propane)
Burner material	Original Professional Black

Top view | Altar Top Side

Complete technical documentation available
via QR-code located above, left

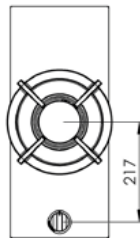

Altar Front Side

Model name	Altar (Front Side)
Output	10,236 BTU
Measurements of unit	L: 503 W: 213 H: 134 mm
Total height	164 mm (incl. supports)
Min. cabinet width	300 mm
Min. counter depth	650 mm
Countertop thickness	4 - 25 mm
Gas	Natural Gas / LPG (Propane)
Burner material	Original Professional Black

Top view | Altar Front Side

Complete technical documentation available
via QR-code located above, left





Azuma Top Side

Model name	Azuma (Top Side)
Output	17,061 BTU
Measurements of unit	L: 503 W: 213 H: 89 mm
Total height	119 mm (incl. supports)
Min. cabinet width	300 mm
Min. counter depth	600 mm
Countertop thickness	4 - 35 mm
Gas	Natural Gas / LPG (Propane)
Burner material	Original
	Professional
	Black

Top view | Azuma Top Side

Complete technical documentation available
via QR-code located above, left

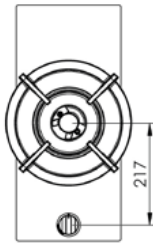

Azuma Front Side

Model name	Azuma (Front Side)
Output	17,061 BTU
Measurements unit	L: 503 W: 213 H: 134 mm
Total height	164 mm (incl. supports)
Min. cabinet width	300 mm
Min. counter depth	650 mm
Countertop thickness	4 - 25 mm
Gas	Natural Gas / LPG (Propane)
Burner material	Original
	Professional
	Black

Top view | Azuma Front Side

Complete technical documentation available
via QR-code located above, left





Model name	Air (Top Side)
Output	17,061 BTU
Measurements unit	L: 503 W: 213 H: 89 mm
Total height	119 mm (incl. supports)
Min. cabinet width	300 mm
Min. counter depth	600 mm
Countertop thickness	4 - 35 mm
Gas	Natural Gas / LPG (Propane)
Burner material	Original Professional Black



Model name	Air (Front Side)
Output	17,061 BTU
Measurements of unit	L: 503 W: 213 H: 134 mm
Total height	164 mm (incl. supports)
Min. cabinet width	300 mm
Min. counter depth	650 mm
Countertop thickness	4 - 25 mm
Gas	Natural Gas / LPG (Propane)
Burner material	Original Professional Black





Baluran Top Side



Model name	Baluran (Top Side)
Output	1x 10,236 BTU, 1x 17,061 BTU
Measurements of unit	L: 503 W: 533 H: 89 mm
Total height	119 mm (incl. supports)
Min. cabinet width	600 mm
Min. counter depth	600 mm
Countertop thickness	4 - 35 mm
Gas	Natural Gas / LPG (propane)
Burner material	Original Professional Black

Top view | Baluran Top Side

Complete technical documentation available via QR-code located above, left

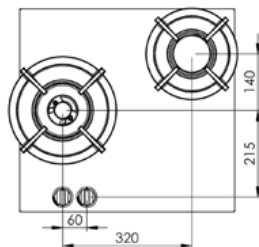

Baluran Front Side

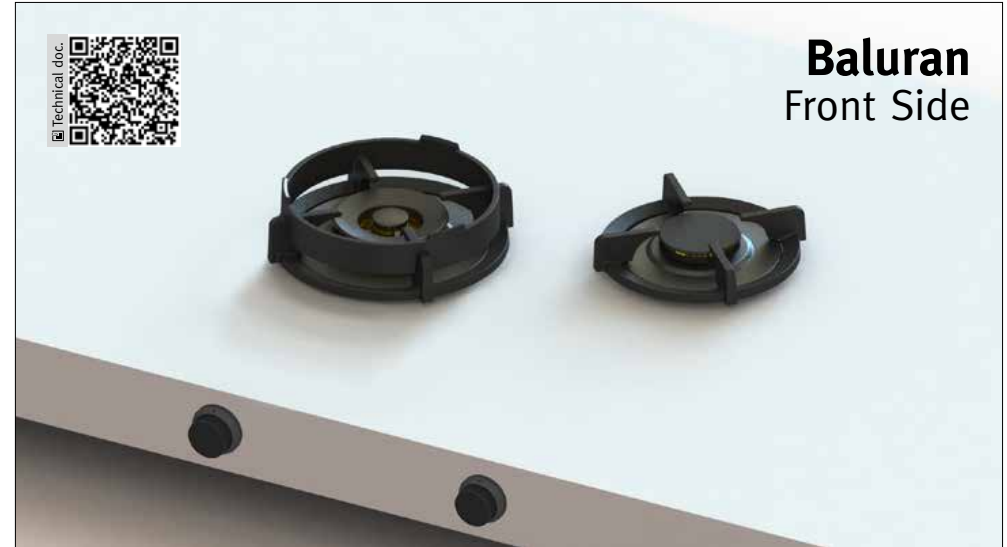

Model name	Baluran (Front Side)
Output	1x 10,236 BTU, 1x 17,061 BTU
Measurements of unit	L: 503 W: 533 H: 134 mm
Total height	164 mm (incl. supports)
Min. cabinet width	600 mm
Min. counter depth	650 mm
Countertop thickness	4 - 25 mm
Gas	Natural gas / LPG (Propane)
Burner material	Original Professional Black

Top view | Baluran Front Side

Complete technical documentation available via QR-code located above, left

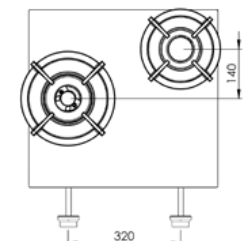



Bennett
Top Side



Model name	Bennett (Top Side)
Output	1x 6,124 BTU, 1X 17,061 BTU
Measurements of unit	L: 503 W: 533 H: 89 mm
Total height	119 mm (incl. support)
Min. cabinet width	600 mm
Min. counter depth	600 mm
Countertop thickness	4 - 35 mm
Gas	Natural Gas / LPG (Propane)
Burner material	Original Professional Black

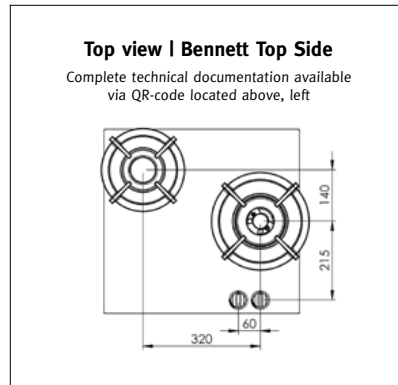

Bennett
Front Side



Model name	Bennett (Front Side)
Output	1x 6,124 BTU, 1X 17,061 BTU
Measurements of unit	L: 503 W: 533 H: 134 mm
Total height	164 mm (incl. supports)
Min. cabinet width	600 mm
Min. counter depth	650 mm
Countertop thickness	4 - 25 mm
Gas	Natural Gas / LPG (Propane)
Burner material	Original Professional Black

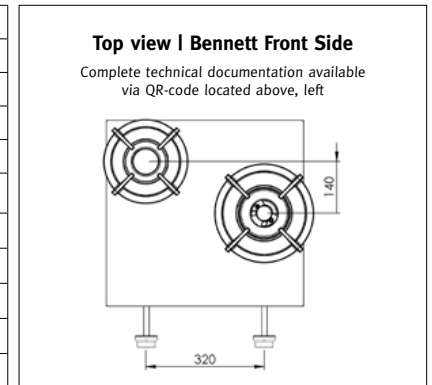



Baula Top Side

Model name	Baula (Top Side)
Output	1x 10,236 BTU, 1x 17,061 BTU
Measurements of unit	L: 403 W: 533 H: 89 mm
Total height	119 mm (incl. supports)
Min. cabinet width	600 mm
Min. counter depth	600 mm
Countertop thickness	4 - 35 mm
Gas	Natural Gas / LPG (Propane)
Burner material	Original Professional Black

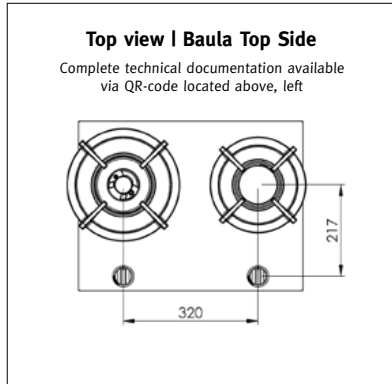

Baula Front Side

Model name	Baula (Front Side)
Output	1x 10,236 BTU, 1x 17,061 BTU
Measurements of unit	L: 403 W: 533 H: 134 mm
Total height	164 mm (incl. supports)
Min. cabinet width	600 mm
Min. counter depth	650 mm
Countertop thickness	4 - 25 mm
Gas	Natural Gas / LPG (Propane)
Burner material	Original Professional Black

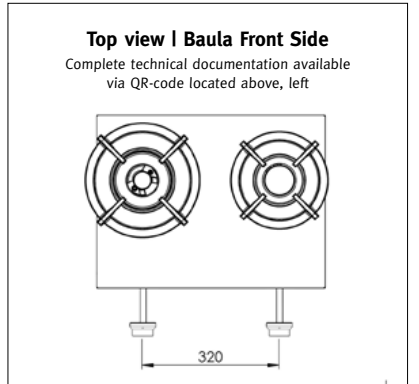



Model name	Bely (Top Side)
Output	1x 6,124 BTU, 1X 17,061 BTU
Measurements of unit	L: 403 W: 533 H: 89 mm
Total height	119 mm (incl. supports)
Min. cabinet width	600 mm
Min. counter depth	600 mm
Countertop thickness	4 - 35 mm
Gas	Natural Gas / LPG (Propane)
Burner material	Original
	Professional
	Black

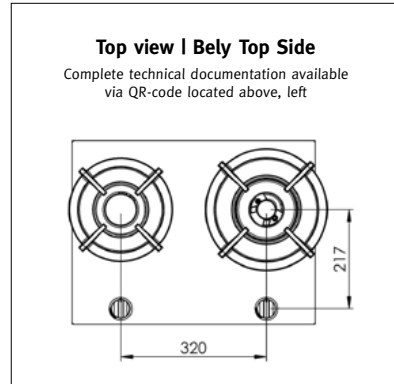

Model name	Bely (Front Side)
Output	1x 6,124 BTU, 1X 17,061 BTU
Measurements of unit	L: 403 W: 533 H: 134 mm
Total height	164 mm (incl. supports)
Min. cabinet width	600 mm
Min. counter depth	650 mm
Countertop thickness	4 - 25 mm
Gas	Natural Gas / LPG (Propane)
Burner material	Original
	Professional
	Black

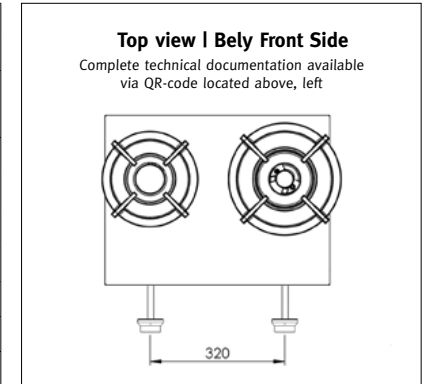



Model name	Bromo (Top Side)
Output	2x 17,061 BTU
Measurements of unit	L: 503 W: 653 H: 89 mm
Total height	119 mm (incl. supports)
Min. cabinet width	700 mm
Min. counter depth	600 mm
Countertop thickness	4 - 35 mm
Gas	Natural Gas / LPG (Propane)
Burner material	Original
	Professional
	Black

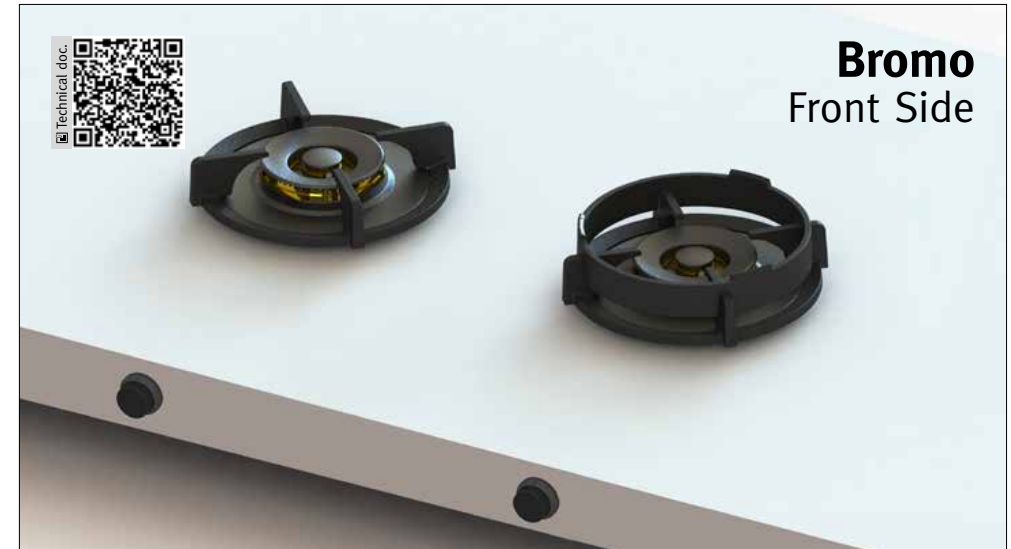
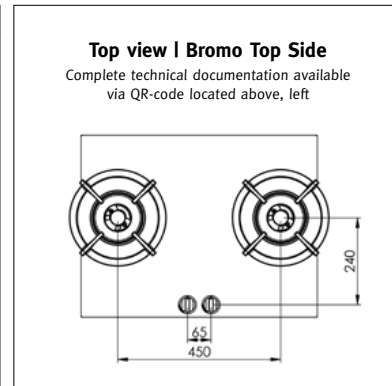

Model name	Bromo (Front Side)
Output	2x 17,061 BTU
Measurements of unit	L: 503 W: 653 H: 134 mm
Total height	164 mm (incl. supports)
Min. cabinet width	700 mm
Min. counter depth	650 mm
Countertop thickness	4 - 25 mm
Gas	Natural Gas / LPG (Propane)
Burner material	Original
	Professional
	Black

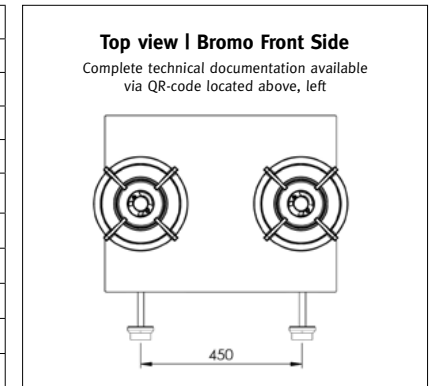



Model name	Cima (Top Side)
Output	1x 6,124 BTU, 1x 10,236 BTU, 1x 17,061 BTU
Measurements of unit	L: 503 W: 533 H: 89 mm
Total height	119 mm (incl. supports)
Min. cabinet width	600 mm
Min. counter depth	600 mm
Countertop thickness	4 - 35 mm
Gas	Natural Gas / LPG (Propane)
Burner material	Original Professional Black

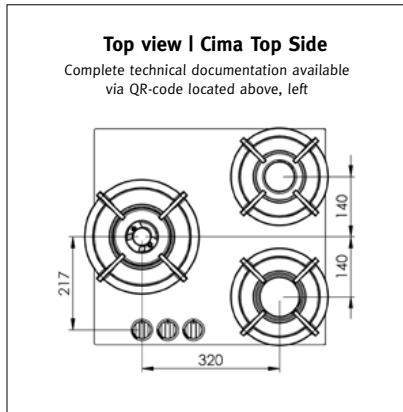

Model name	Cima (Front Side)
Output	1x 6,124 BTU, 1x 10,236 BTU, 1x 17,061 BTU
Measurements of unit	L: 503 W: 533 H: 134 mm
Total height	164 mm (incl. supports)
Min. cabinet width	600 mm
Min. counter depth	650 mm
Countertop thickness	4 - 25 mm
Gas	Natural Gas / LPG (Propane)
Burner material	Original Professional Black

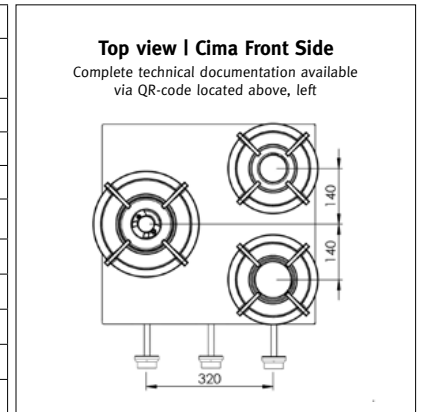



Capital Top Side



Model name	Capital (Top Side)
Output	1x 6,124 BTU, 1x 10,236 BTU, 1x 17,061 BTU
Measurements of unit	L: 503 W: 533 H: 89 mm
Total height	119 mm (incl. supports)
Min. cabinet width	600 mm
Min. counter depth	600 mm
Countertop thickness	4 - 35 mm
Gas	Natural Gas / LPG (Propane)
Burner material	Original Professional Black

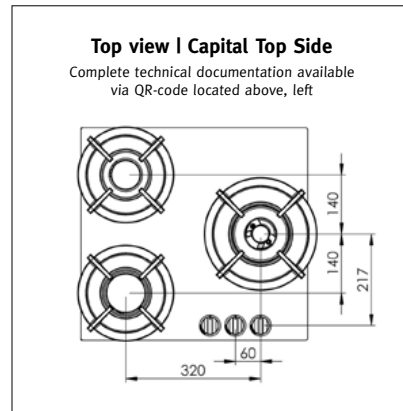

Capital Front Side



Model name	Capital (Front Side)
Output	1x 6,124 BTU, 1x 10,236 BTU, 1x 17,061 BTU
Measurements of unit	L: 503 W: 533 H: 134 mm
Total height	164 mm (incl. supports)
Min. cabinet width	600 mm
Min. counter depth	650 mm
Countertop thickness	4 - 25 mm
Gas	Natural Gas / LPG (Propane)
Burner material	Original Professional Black

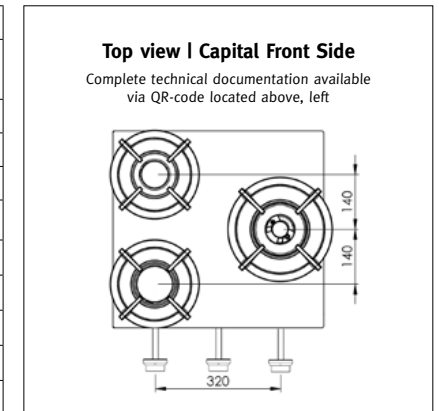



Cusin Top Side



Model name	Cusin (Top Side)
Output	1x 10,236 BTU 2x 17,061 BTU
Measurements of unit	L: 403 W: 853 H: 89 mm
Total height	119 mm (incl. supports)
Min. cabinet width	900 mm
Min. counter depth	600 mm
Countertop thickness	4 - 35 mm
Gas	Natural Gas / LPG (Propane)
Burner material	Original Professional Black

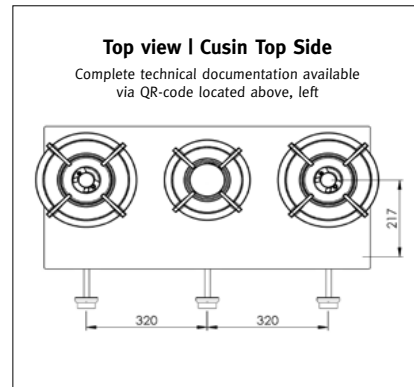

Cusin Front Side



Model name	Cusin (Front Side)
Output	1x 10,236 BTU 2x 17,061 BTU
Measurements of unit	L: 403 W: 853 H: 134 mm
Total height	164 mm (incl. supports)
Min. cabinet width	900 mm
Min. counter depth	650 mm
Countertop thickness	4 - 25 mm
Gas	Natural Gas / LPG (Propane)
Burner material	Original Professional Black

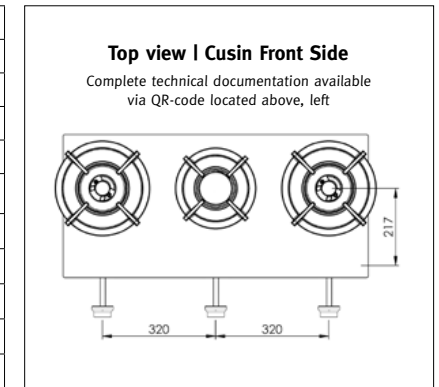



Model name	Colo (Top Side)
Output	1x 6,124 BTU, 2x 17,061 BTU
Measurements of unit	L: 503 W: 853 H: 89 mm
Total height	119 mm (incl. supports)
Min. cabinet width	900 mm
Min. counter depth	600 mm
Countertop thickness	4 - 35 mm
Gas	Natural Gas / LPG (Propane)
Burner material	Original Professional Black

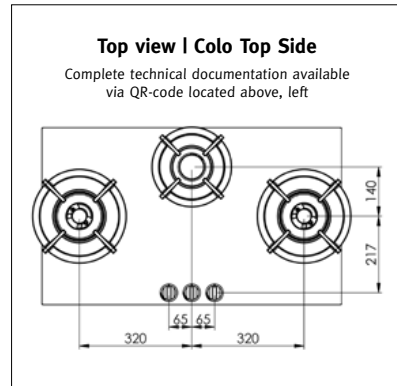

Model name	Colo (Front Side)
Output	1x 6,124 BTU, 2x 17,061 BTU
Measurements of unit	L: 503 W: 853 H: 134 mm
Total height	164 mm (incl. supports)
Min. cabinet width	900 mm
Min. counter depth	650 mm
Countertop thickness	4 - 25 mm
Gas	Natural Gas / LPG (Propane)
Burner material	Original Professional Black

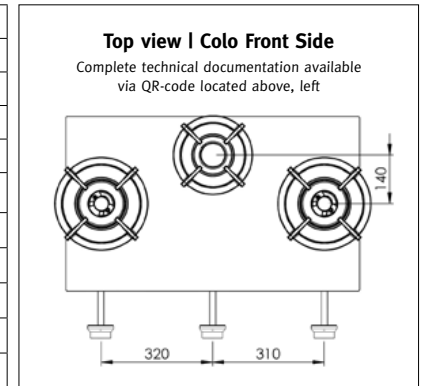



Model name	Danau (Top Side)
Output	1x 6,124 BTU, 1x 10,236 BTU, 2x 17,061 BTU
Measurements of unit	L: 403 W: 1157 H: 89 mm
Total height	119 mm (incl. supports)
Min. cabinet width	1200 mm
Min. counter depth	600 mm
Countertop thickness	4 - 35 mm
Gas	Natural Gas / LPG (Propane)
Burner material	Original Professional Black

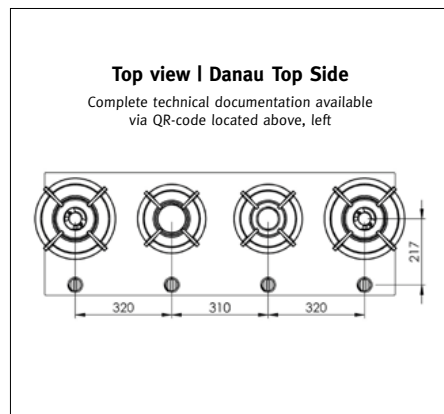

Model name	Danau (Front Side)
Output	1x 6,124 BTU, 1x 10,236 BTU, 2x 17,061 BTU
Measurements of unit	L: 403 W: 1157 H: 134 mm
Total height	164 mm (incl. supports)
Min. cabinet width	1200 mm
Min. counter depth	650 mm
Countertop thickness	4 - 25 mm
Gas	Natural Gas / LPG (Propane)
Burner material	Original Professional Black

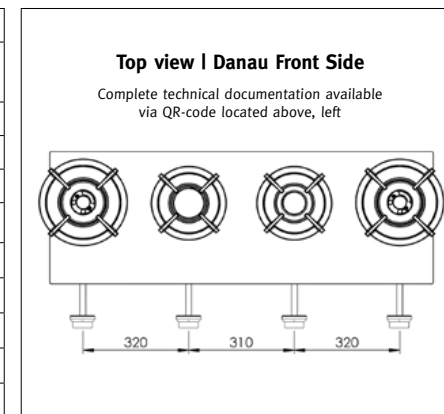



Drum Top Side

Model name	Drum (Top Side)
Output	1x 6,124 BTU, 1x 10,236 BTU, 2x 17,061 BTU
Measurements of unit	L: 503 W: 1157 H: 89 mm
Total height	119 mm (incl. supports)
Min. cabinet width	1200 mm
Min. counter depth	600 mm
Countertop thickness	4 - 35 mm
Gas	Natural Gas / LPG (Propane)
Burner material	Original Professional Black

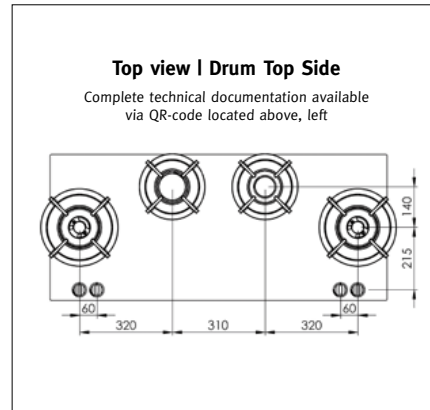

Drum Front Side

Model name	Drum (Front Side)
Output	1x 6,124 BTU, 1x 10,236 BTU, 2x 17,061 BTU
Measurements of unit	L: 503 B: 1157 H: 134 mm
Total height	164 mm (incl. supports)
Min. cabinet width	1200 mm
Min. counter depth	650 mm
Countertop thickness	4 - 25 mm
Gas	Natural Gas / LPG (Propane)
Burner material	Original Professional Black

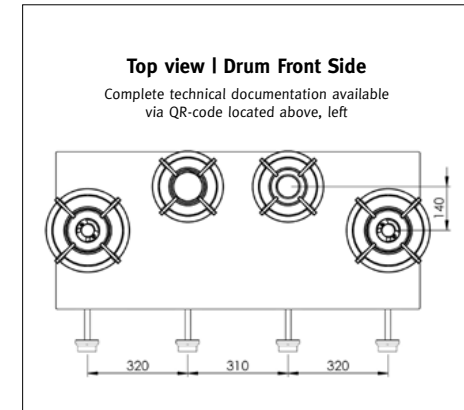

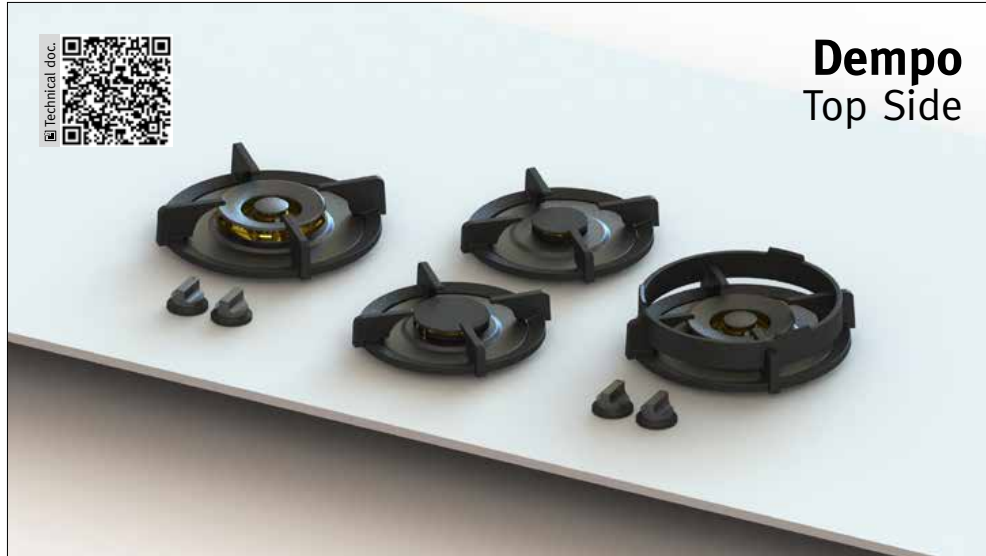

Model name	Dempo (Top Side)
Output	1x 6,124 BTU, 1x 10,236 BTU, 2x 17,061 BTU
Measurements of unit	L: 503 B: 853 H: 89 mm
Total height	119 mm (incl. supports)
Min. cabinet width	900 mm
Min. counter depth	600 mm
Countertop thickness	4 - 35 mm
Gas	Natural Gas / LPG (Propane)
Burner material	Original Professional Black

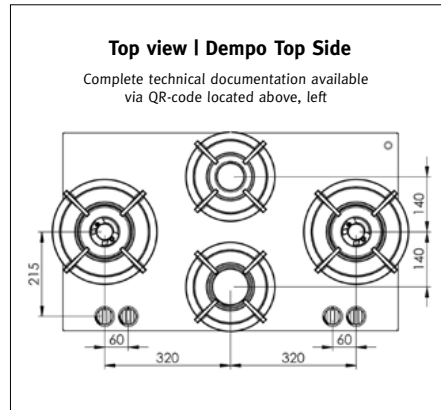

Model name	Dempo (Front Side)
Output	1x 6,124 BTU, 1x 10,236 BTU, 2x 17,061 BTU
Measurements of unit	L: 503 B: 853 H: 134 mm
Total height	164 mm (incl. supports)
Min. cabinet width	900 mm
Min. counter depth	650 mm
Countertop thickness	4 - 25 mm
Gas	Normal Gas / LPG (Propane)
Burner material	Original Professional Black

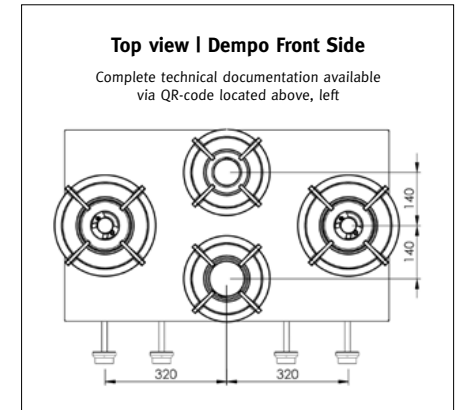



Elbrus Top Side



Model name	Elbrus (Top Side)
Output	2x 6,142 BTU, 2x 10,236 BTU, 1x 17,061 BTU
Measurements of unit	L: 503 B: 853 H: 89 mm
Total height	119 mm (incl. supports)
Min. cabinet width	900 mm
Min. counter depth	600 mm
Countertop thickness	4 - 35 mm
Gas	Natural Gas / LPG (Propane)
Burner material	Original Professional Black

Top view | Elbrus Top Side

Complete technical documentation available
via QR-code located above, left

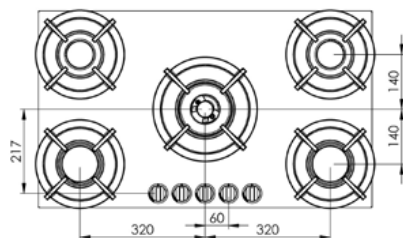

Elbrus Front Side



Model name	Elbrus (Front Side)
Output	2x 6,142 BTU, 2x 10,236 BTU, 1x 17,061 BTU
Measurements of unit	L: 503 B: 853 H: 134 mm
Total height	164 mm (incl. supports)
Min. cabinet width	900 mm
Min. counter depth	650 mm
Countertop thickness	4 - 25 mm
Gas	Natural Gas / LPG (Propane)
Burner material	Original Professional Black

Top view | Elbrus Front Side

Complete technical documentation available
via QR-code located above, left

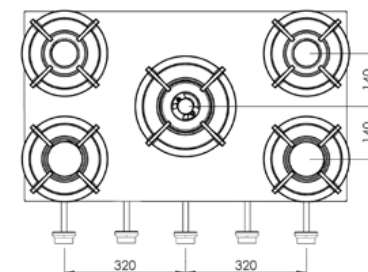



Model name	Enep (Top Side)
Output	2x 6,142 BTU, 2x 10,236 BTU, 1x 17,061 BTU
Measurements of unit	L: 503 B: 853 H: 89 mm
Total height	119 mm (incl. supports)
Min. cabinet width	900 mm
Min. counter depth	600 mm
Countertop thickness	4 - 35 mm
Gas	Natural Gas / LPG (Propane)
Burner material	Original Professional Black

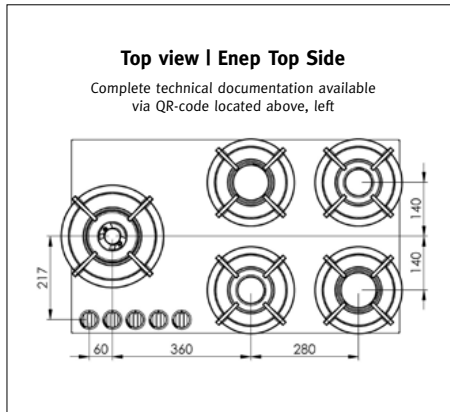

Model name	Enep (Front Side)
Output	2x 6,142 BTU, 2x 10,236 BTU, 1x 17,061 BTU
Measurements of unit	L: 503 B: 853 H: 134 mm
Total height	164 mm (incl. supports)
Min. cabinet width	900 mm
Min. counter depth	650 mm
Countertop thickness	4 - 25 mm
Gas	Natural Gas / LPG (Propane)
Burner material	Original Professional Black

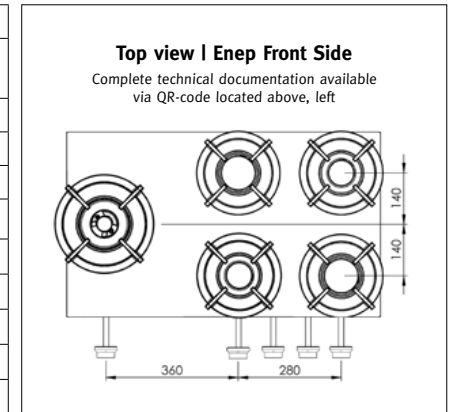



Model name	Ebeko (Top Side)
Output	2x 6,142 BTU, 2x 10,236 BTU, 1x 17,061 BTU
Measurements of unit	L: 503 B: 853 H: 89 mm
Total height	119 mm (incl. supports)
Min. cabinet width	900 mm
Min. counter depth	600 mm
Countertop thickness	4 - 35 mm
Gas	Natural Gas / LPG (Propane)
Burner material	Original Professional Black

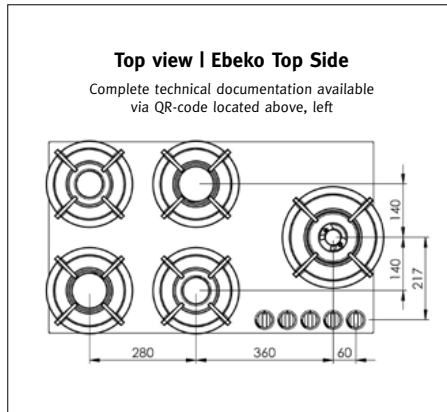

Model name	Ebeko (Front Side)
Output	2x 6,142 BTU, 2x 10,236 BTU, 1x 17,061 BTU
Measurements of unit	L: 503 B: 853 H: 134 mm
Total height	164 mm (incl. supports)
Min. cabinet width	900 mm
Min. counter depth	650 mm
Countertop thickness	4 - 25 mm
Gas	Natural Gas / LPG (Propane)
Burner material	Original Professional Black

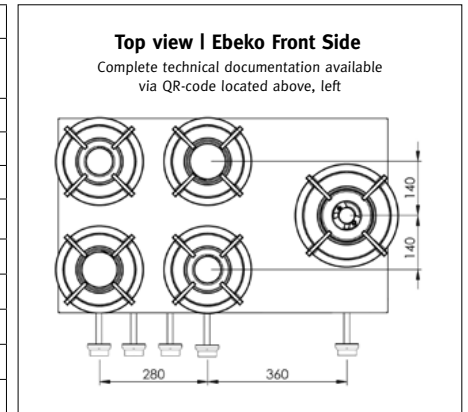



Foessa Top Side



Model name	Foessa (Top Side)
Output	2x 6,142 BTU, 2x 10,236 BTU, 2x 17,061 BTU
Measurements of unit	L: 503 B: 1157 H: 89 mm
Total height	119 mm (incl. supports)
Min. cabinet width	1200 mm
Min. counter depth	600 mm
Countertop thickness	4 - 35 mm
Gas	Natural Gas / LPG (Propane)
Burner material	Original Professional Black

Top view | Foessa Top Side

Complete technical documentation available
via QR-code located above, left

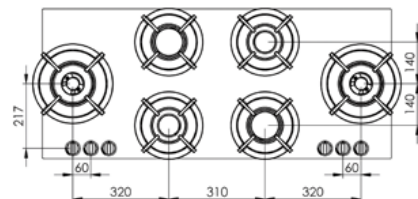

Foessa Front Side



Model name	Foessa (Front Side)
Output	2x 6,142 BTU, 2x 10,236 BTU, 2x 17,061 BTU
Measurements of unit	L: 503 B: 1157 H: 134 mm
Total height	164 mm (incl. supports)
Min. cabinet width	1200 mm
Min. counter depth	650 mm
Countertop thickness	4 - 25 mm
Gas	Natural Gas / LPG (Propane)
Burner material	Original Professional Black

Top view | Foessa Front Side

Complete technical documentation available
via QR-code located above, left

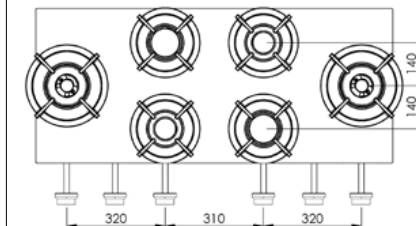



Only available in Front Side

Bandai Front Side

Model name	Bandai (Front Side)
Output	1x 6,142 BTU, 1x 10,236 BTU
Measurements of unit	L: 503 B: 433 H: 134 mm
Total height	164 mm (incl. supports)
Min. cabinet width	600 mm
Min. counter depth	650 mm
Countertop thickness	4 - 25 mm
Gas	Natural Gas / LPG (Propane)
Burner material	Original
	Professional
	Black

Top view | Bandai Front Side

Complete technical documentation available via QR-code located above, left

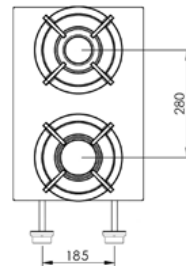

Wok ring

Included with every model that has 1 or more Simmer/Stir Fry burners.

Made of	Sast iron
Circumference	ø248 mm
Height	51,1 mm

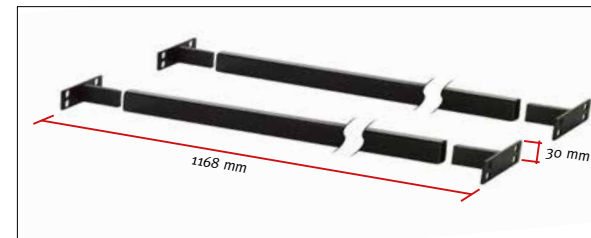
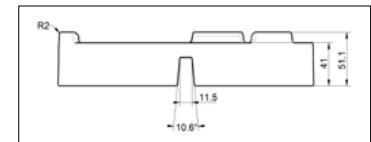

Support bars

1 set included with every module.

Made of	Powder coated steel
Length	1168 mm
Height	30 mm

The PITT cooking module: top

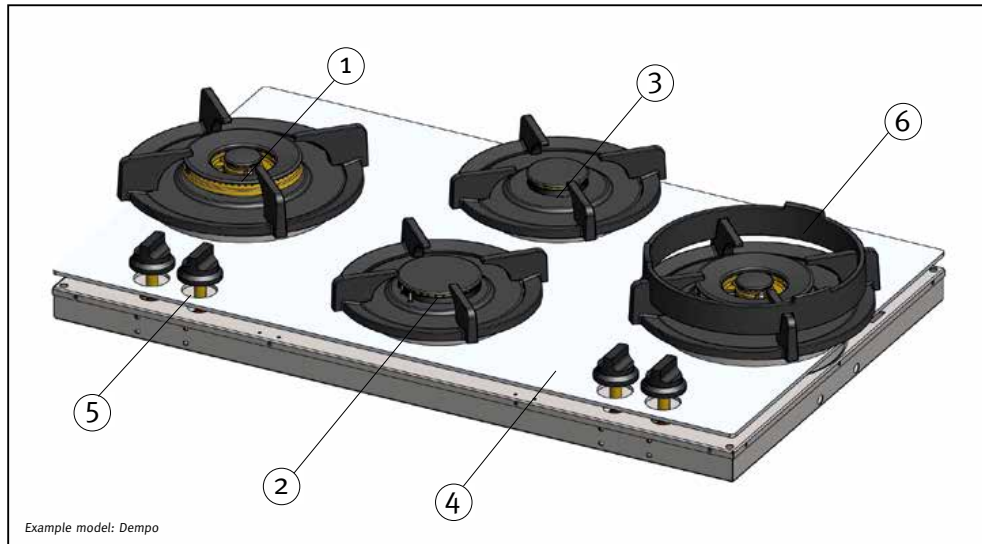

Number	Item	Page
1	Combined Simmer/Stir Fry burner	126
2	Medium burner	122-125
3	Small burner	122-125
4	Heat diffuser	See installation instructions starting on page 145
5	Control knob Also may be installed on the front (vertical) side of the countertop	128-129
6	Wok ring	127

The PITT cooking module: bottom

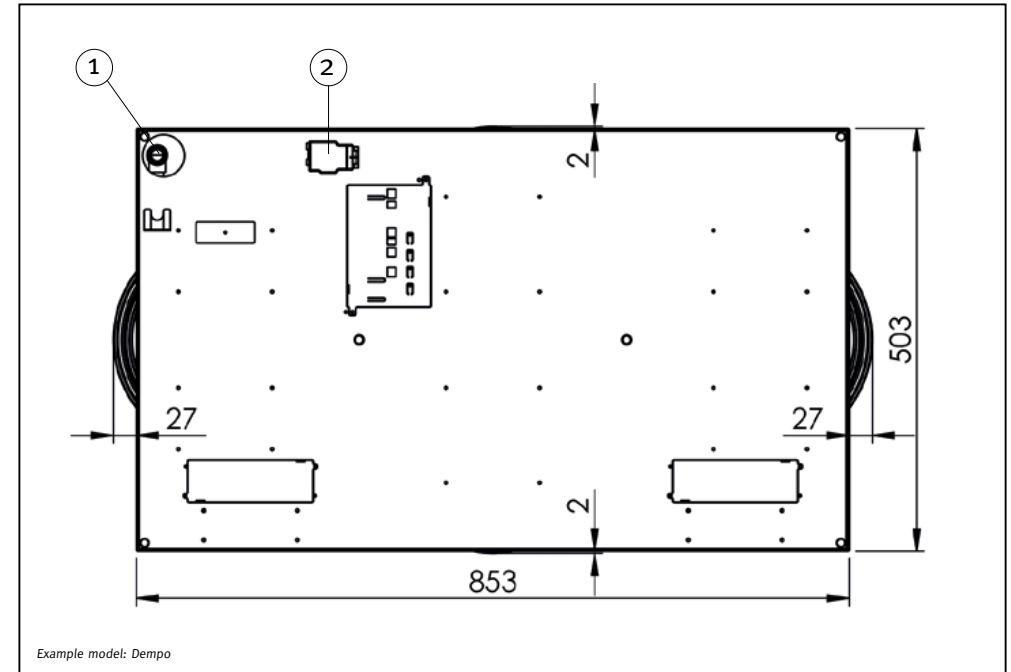

Number	Item	Page
1	Gas connection	131
2	Electrical connection	131

The burners

– Three types of burners: Small, Medium, Simmer/Stir Fry (combined)

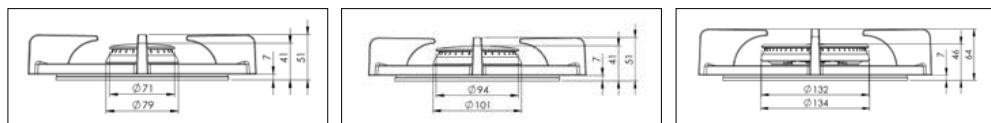
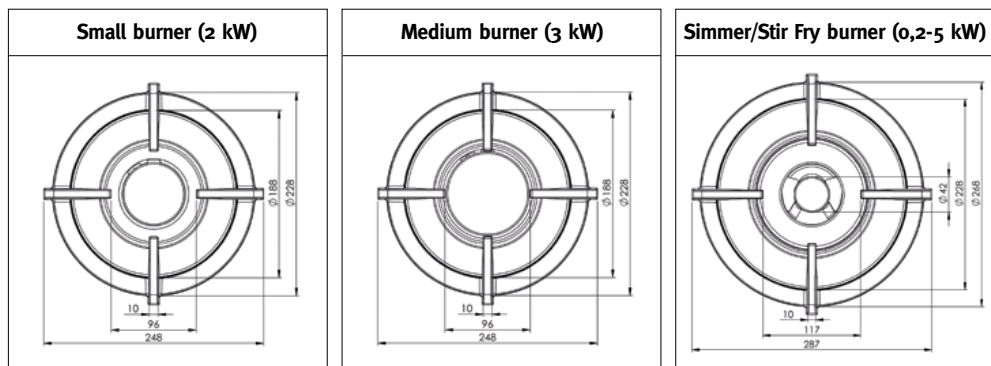

Type of burner	Minimum output	Maximum output	Circumference	Material
Small burner	1,024 BTU	6,142 BTU	ø230 mm	Original Professional Black
Medium burner	1,024 BTU	10,236 BTU	ø230 mm	Original Professional Black
Simmer/Stir Fry burner (combined)	682 BTU	17,061 BTU	ø270 mm	Original Professional Black

The burners

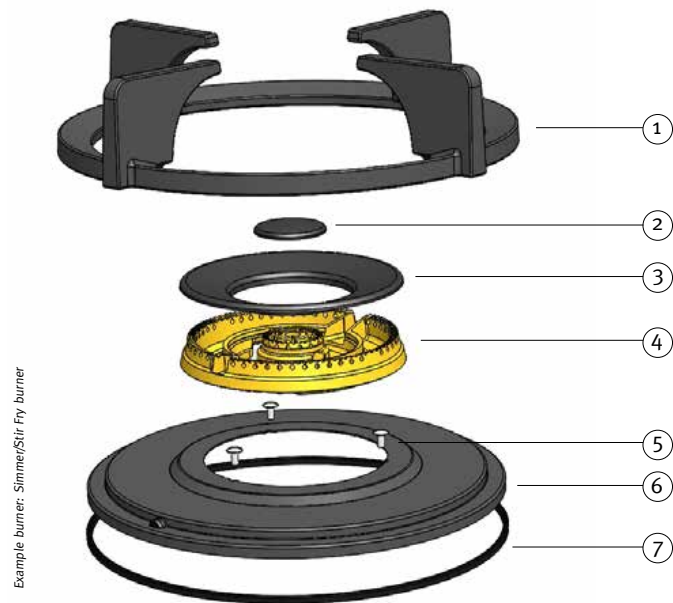

Example burner: Simmer/Stir Fry burner

Number	Item	Material	Number	Item	Material
1	Grate	Enameled cast iron	5	Mounting	Stainless Steel
2	Burner head flame distributor (cap)	Enameled cast iron	6	Heat shield	Enameled steel
3	Burner head flame distributor (ring)	Enameled cast iron	7	Silicone ring	Silicone
4	Vlamverdeler	Aluminum (Original) Brass (Professional & Black)			

Burner function

– What makes the PITT cooking burner efficient?

In order to produce an efficient flame it is essential that the correct ratio and mixture of gas and oxygen is achieved. Correctly calibrated burning, gas pressure and gas composition produces a perfect blue flame. How is this achieved?

1. Calibration and calculation

- At PITT cooking the ratio of air flow and gas supply feed have been very precisely calculated and applied during the product design process: all the various (technical) parts within the cooking system are finely tuned to one another on the basis of these calculations.
- The PITT cooking system achieves precisely calculated gas supply feed by the orifices in accordance with the type of gas and gas pressure.

2. Airflow intake

Delivery of oxygen is efficient:

- Air intake is different from that of other burners in that it comes from above and travels unimpeded to the burner. In this way there is neither resistance nor loss of air delivery. This results in very low gas usage by the burner.
- The floating grate further promotes optimal air delivery to the burner unit.

3. Testing

During the in house production process each burner is tested for optimal function and efficiency with each type of gas and the applicable gas pressure for each.

Burner function

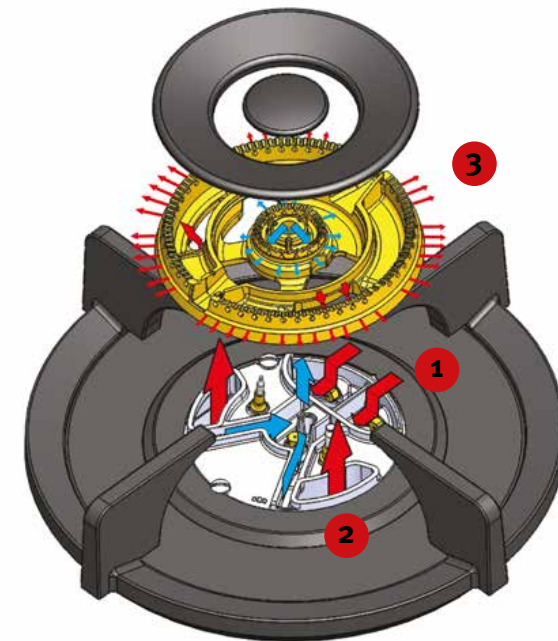

1

Gas flow is activated. Gas mixes with oxygen.

2

The gas-oxygen mixture is forced upwards.

3

The gas-oxygen mixture ignites and exits the burner head.

Simmer/Stir Fry burner (combined)

— How the combined Simmer/Stir Fry burner works

■ Gas supply feed



Control knob in closed position:
Gas supply off.



Control knob at the half open position:
Gas supply fully open.
Both rings are activated.



Control knob completely open:
Gas supply partially open.
Only the smaller ring is activated.

The Simmer/Stir Fry burner is controlled by a single knob:

- By opening the knob half way the gas supply goes to both rings: a large outer ring and a smaller inner ring. Both will ignite whereby a powerful, high (stir fry) flame results.
- By opening the knob to the fully open position gas is supplied only to the smaller inner ring. A small, gentle (simmering) flame results.

Wok ring

Points of attention

- The PITT cooking Wok Ring is a loose accessory especially designed for use on PITT burners with woks that have a rounded bottom.
- A PITT cooking wok ring is included with every model that has one or more Simmer/Stir Fry burners.

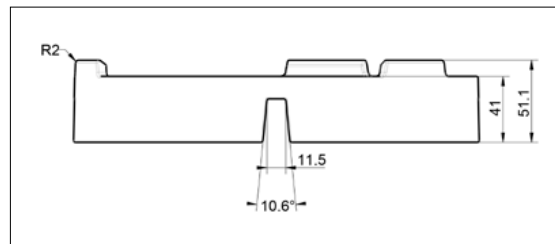
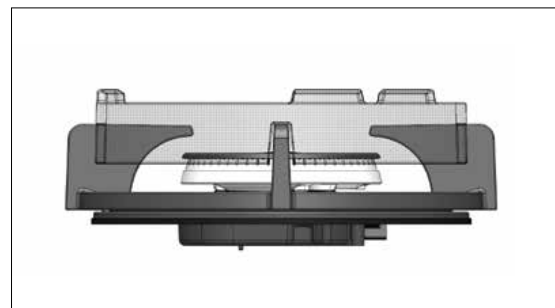

— Design and function

- Chinese wok stir fry technique is the basis for the design.
- The three extended arms offer a stable base to the rounded pan at all times.
- The precisely calculated height and rounding of the ring cause the flames to hit the pan with precise control at just the right place.
- The wok ring is designed for use on the PITT cooking Simmer/Stir Fry burner.

The control knob: placement

For each PITT cooking module you can select one of two different locations for the control knobs:

- **Top Side operation:** knobs on the countertop
- **Front Side operation:** knobs on the front (vertical) side of the countertop

– Module with Top Side operation

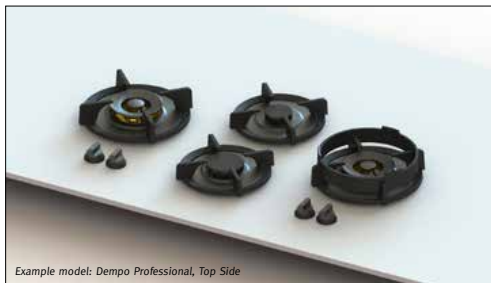

Example model: Dempo Professional, Top Side

– Module with Front Side operation



Example model: Dempo Professional, Front Side

Important

Countertop integration of PITT Top Side models differs in several respects from that of PITT Front Side models. This regards:

- **Dimensions/construction measurements:** See page 132 (Top Side) and page 136 (Front Side)
- **Installation:** See page 145 (Top Side) and page 148 (Front Side)
- **How to order:** See page 155

The control knob: dimensions

– Dimensions of Top Side control knob



3D rendering of Top Side knob

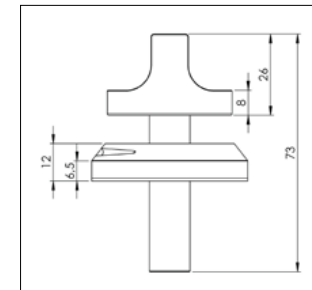

Front view of Top Side knob

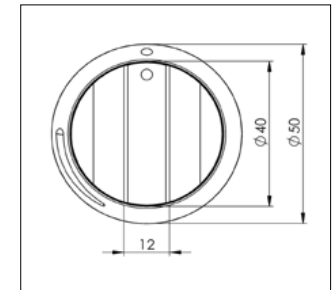

Overhead view of Top Side knob

– Dimensions of Front Side control knob



3D rendering of Front Side knob

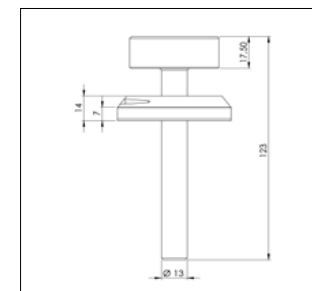

Front view of Front Side knob

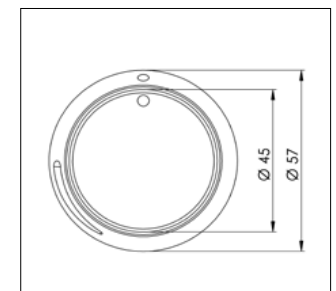

Overhead view of Front Side knob

Countertop requirements

Important

- Caution: The countertop requirements for PITT cooking models with Top Side controls (see page 133 for construction measurements) differ from those for models with Front Side controls (for construction measurements see page 136). You will find further information about making the countertop cutouts starting on page 137.

– Which materials are suitable for safe installation of PITT cooking modules?

Suitable:

- ✓ Compact Board
- ✓ Quartz Composite
- ✓ Fenix NTM
- ✓ Concrete
- ✓ Glass
- ✓ Natural stone (e.g. Granite, marble)
- ✓ Stainless Steel
- ✓ Ceramic



Unsuitable

- ✗ Countertops with an HPL top layer (High Pressure Laminate)
- ✗ Solid wood
- ✗ Solid Surface



Requirements for gas and electrical connections

Important

- The shutoff valve, wall receptacle and plug must all remain within easy reach.
- Installation and connections must comply with all current local and state regulations. In this regard very close attention must be paid to ventilation requirements.

– Positioning of gas and electrical connections

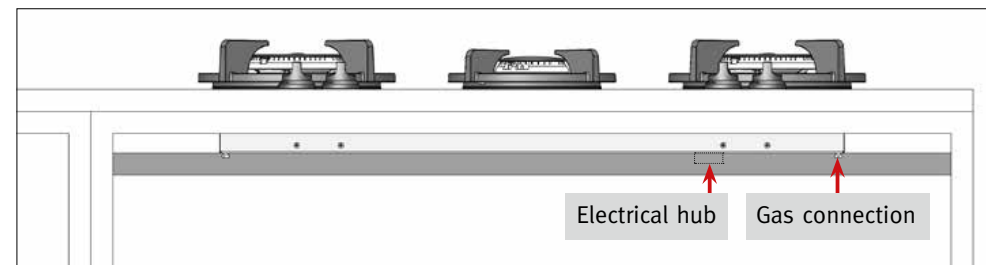

– Gas

Suitable gas supplies	Natural gas LPG (Propane)
Type of connection	1/2" external thread

– Electricity

Voltage	220-110V (default) 1,5V (on request)
Wire length	150 cm

– Spark ignition and flame protection

Automatic ignition	✓
Flame protection (thermo couple)	✓

Construction measurements: Top Side

– Installation dimensions for Top Side models (measurements in mm)

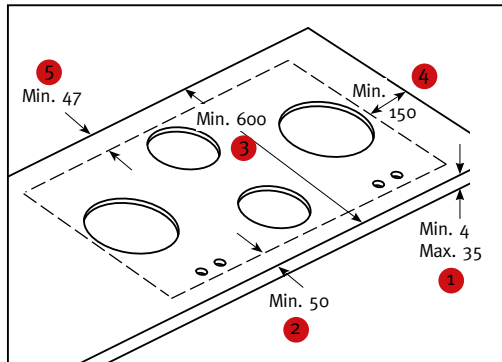

1	Minimum thickness of countertop material (solid)	4 mm
	<i>Minimum thickness of countertop material (solid)</i>	10 mm
1	Maximum thickness of board material (solid)	35 mm
2	Minimum C-size	50 mm
3	Minimum depth of countertop	600 mm
4	Minimum distance from the sides of the countertop	150 mm
5	Minimum distance from the back of the countertop	47 mm

Construction measurements: Top Side

– Construction measurements for Top Side models (measurements in mm)

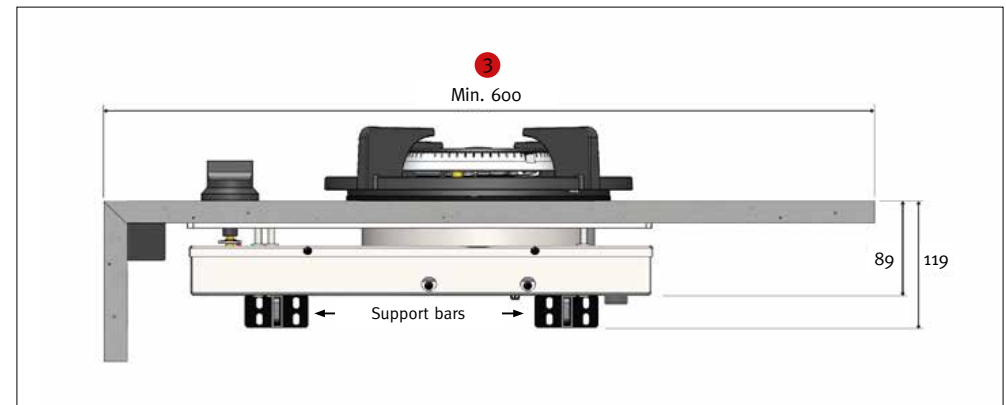
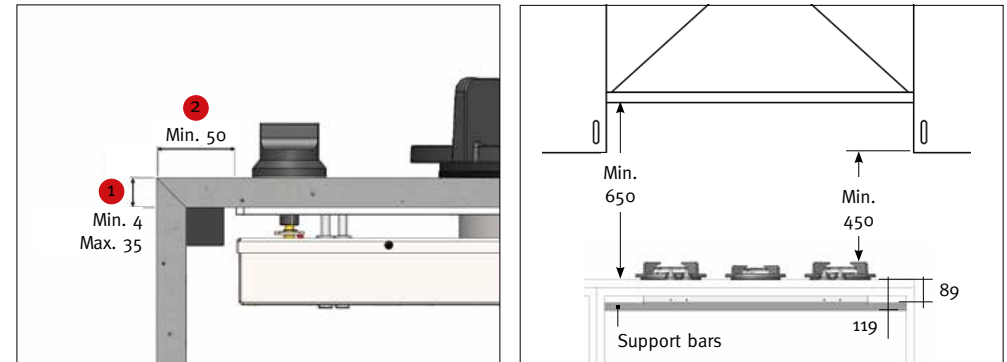

Construction measurements: Front Side

– Construction measurements for Front Side models (dimensions in mm)

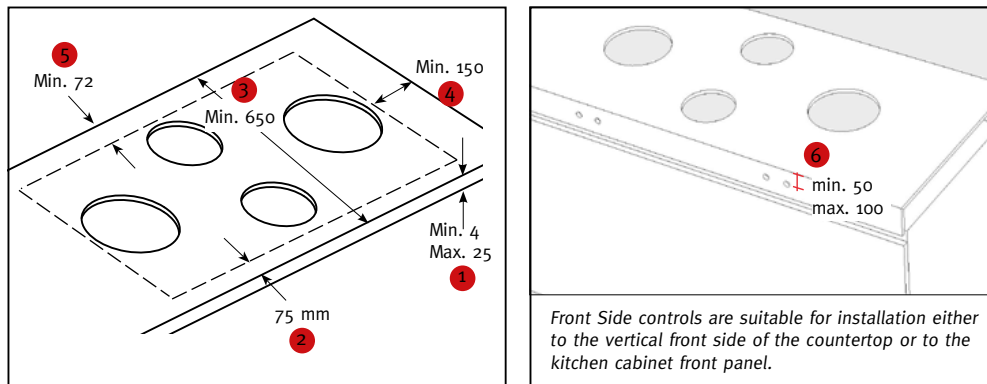

Front Side controls are suitable for installation either to the vertical front side of the countertop or to the kitchen cabinet front panel.

1	Minimum thickness of countertop material (solid)	4 mm
	Minimum thickness of countertop material (solid) of: Quartz Composite, compact board and natural stone	10 mm
1	Maximum thickness of countertop material	25 mm
2	Fixed C-size	75 mm
3	Minimum depth of countertop	650 mm
4	Minimum distance from sides of countertop	150 mm
5	Minimum distance from the back of countertop	72 mm
6	Center of the control knob, with reference to top of countertop	Min. 50 Max. 100 mm

Construction measurements: Front Side

– Construction measurements for Front Side models (dimensions in mm)

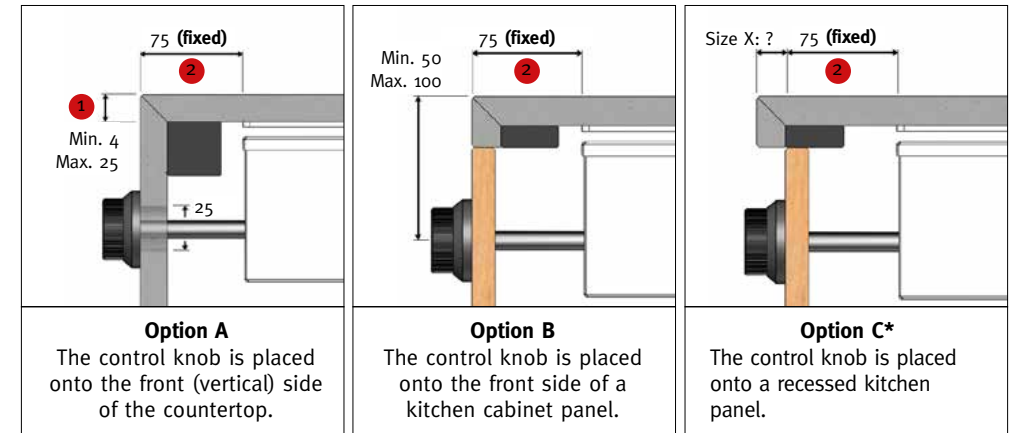

Option A

The control knob is placed onto the front (vertical) side of the countertop.

Option B

The control knob is placed onto the front side of a kitchen cabinet panel.

Option C*

The control knob is placed onto a recessed kitchen panel.

Placement of control knob (height)

The placement of the knob (height) can be established during the cabinetry design process. Take into account the minimum distance of 50 cm and maximum distance of 100 cm from the top surface of the countertop.

* With this option take into account the amount of countertop overhang. (Dimension X)



Template measurements

Dimensions Template

In order to execute the correct dimensions you should make use of a dimensions template when ordering a Front Side model. You can download this template via the QR-code on the left, or via the website: pittcooking.com/downloads.

Installation measurements: Front Side

– Installation measurements for Front Side models (measurements in mm)

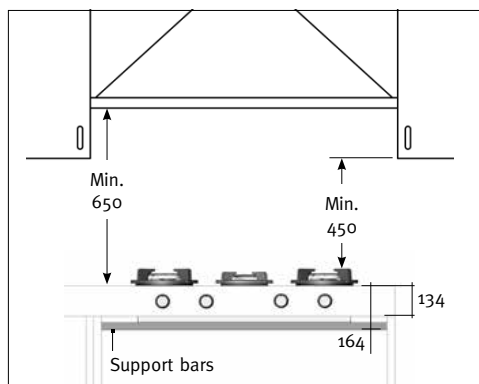
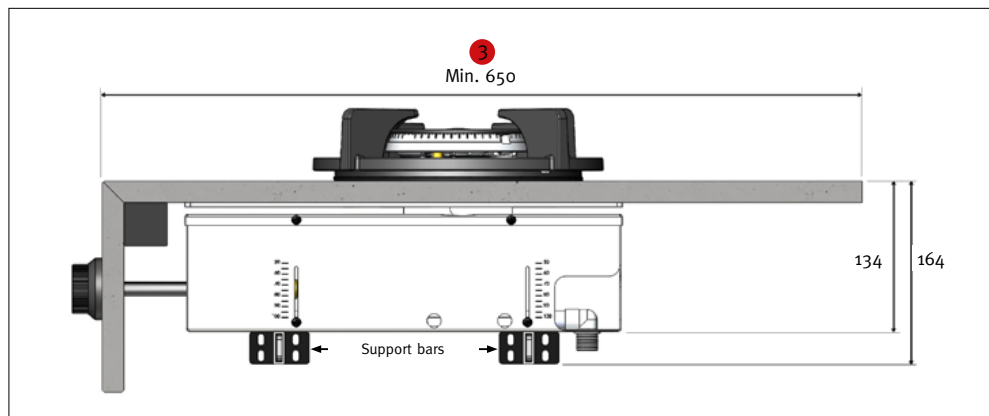

Cutouts

Cutout patterns

The cutouts in the countertop should be made by using the cutout pattern for the applicable model. Cutout patterns for all models can be found on page 158 under 'Downloads'. They are also on the PITT cooking website: pittcooking.com/assortment (on the applicable model's page) or via pittcooking.com/downloads.

– Points of attention

- The inside of the cutout(s) must be smooth and even and must be carefully sanded (fig. A1). Irregularities can cause cracks (fig. A2).

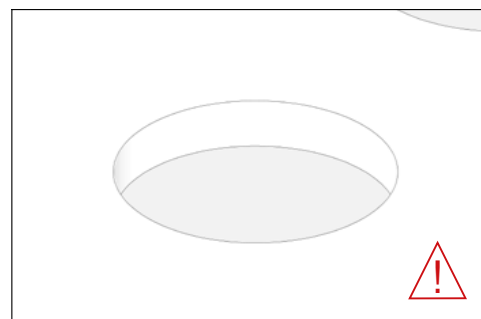

Fig. A1

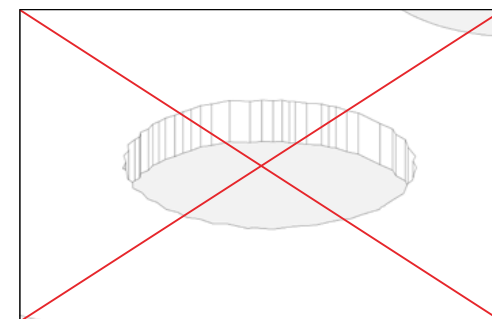

Fig. A2

Cutouts

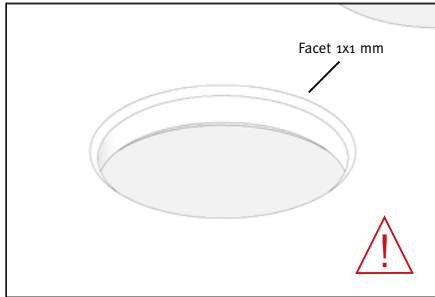

Fig. A3

- Create a very small 1x1 mm facet on both the upper and lower edges of the cutouts (Fig. A3).

- Glued connections and/or coupling joints may never intersect the cutout(s). Joints must be a minimum distance of 250 mm from any cutout(s) (fig. A4 and fig. A5).

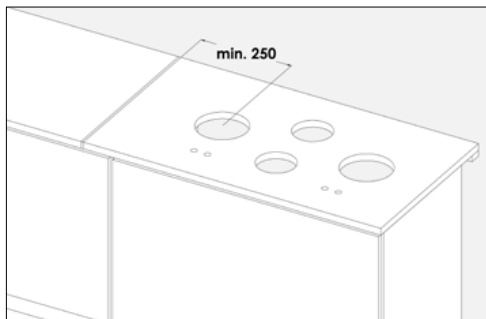

Fig. A4

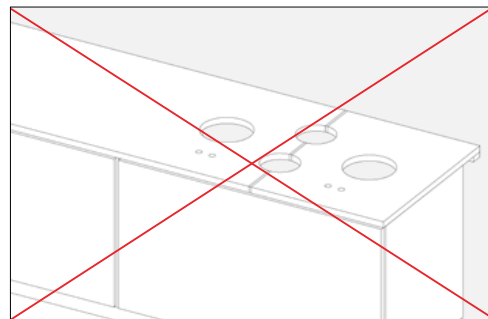
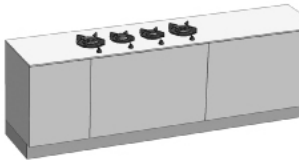

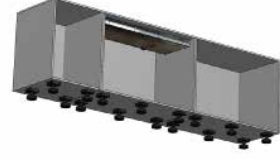

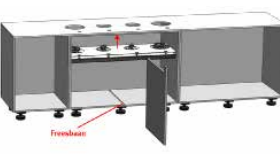
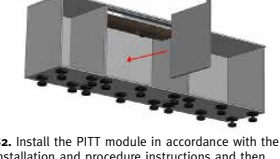

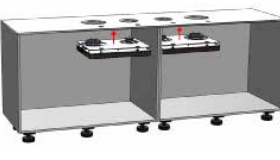

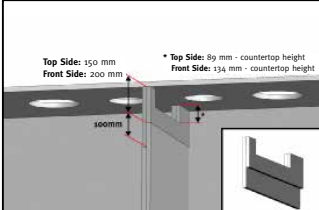
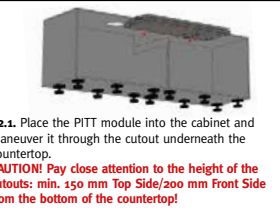
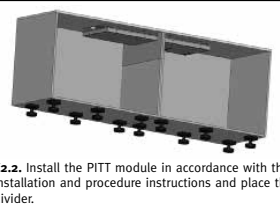
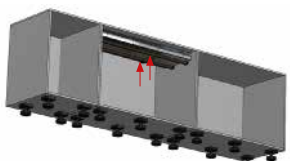

Fig. A5

Construction: checklist

 <p>Option A: 1 cabinet</p>	 <p>A1. Position the PITT module in the cabinet.</p>	 <p>A2. Install the PITT module in accordance with the installation and procedure instructions.</p>
 <p>Option B: 2 cabinets</p>	 <p>B1. Remove the center wall of the cabinet and place the PITT module into the cabinet.</p>	 <p>B2. Install the PITT module in accordance with the installation and procedure instructions and then slide the center wall back in by way of a routed groove.</p>
 <p>Option C: 2 cabinets</p>	 <p>C1. Place two individual PITT modules into the two cabinets.</p>	 <p>C1.2. Install the two PITT modules in accordance with the installation and procedure instructions.</p>
	 <p>C2.1. Place the PITT module into the cabinet and maneuver it through the cutout underneath the countertop. CAUTION! Pay close attention to the height of the cutouts: min. 150 mm Top Side/200 mm Front Side from the bottom of the countertop!</p>	 <p>C2.2. Install the PITT module in accordance with the installation and procedure instructions and place the divider.</p>

Construction: checklist



A3. Install the PITT cooking pair of support bars in accordance with the instructions.

Option A:

The module is installed within the breadth of one single cabinet. Pay attention to the proper positioning of the pair of support bars.

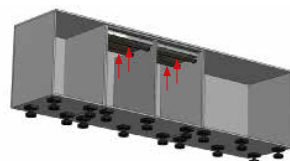

B3. Install the two pairs of PITT cooking support bars in accordance with the instructions.

Option B:

The module is installed over the junction of two cabinets. Provide for a removable divider via a routed groove.

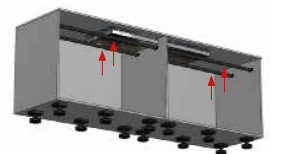

C1.3. Install the two pairs of Pitt cooking support bars in accordance with the instructions.

Option C1:

The module is installed over the junction of two cabinets. Combine two individual PITT modules each of which fits within the breadth of a single cabinet.

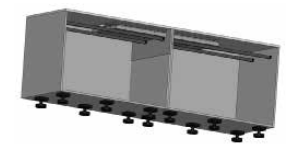

C2.3. Install the PITT support bars in accordance with the instructions.

Option C2:

The module is installed over the junction of two cabinets. Provide a removable divider that complies with the correct minimum heights.

Installation: instructions

Important

- It is extremely important to assure that a PITT Module is removable in the event that service is required. In order to verify that a module adheres to established construction requirements please see the construction checklist on page 142.
- In order to avoid sagging of the countertop it is essential to support it by installing the support bars provided. Instructions for installation of the support bars can be found on page 151.
- The underside of the countertop material must be completely smooth in order for contact between the heat diffuser and the countertop to be uninterrupted.
- Attention: for models with Top Side controls (page 145) the installation instructions differ from those for models with Front Side controls (page 148).

Installation of a Top Side module

Below you will find a step by step guide to the installation of a PITT cooking module with Top Side controls.



In order to protect the guarantee and assure proper functioning of the cooking unit, it's essential to follow and execute the installation guidelines precisely.

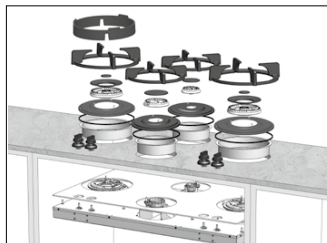

1. Overview of all parts.

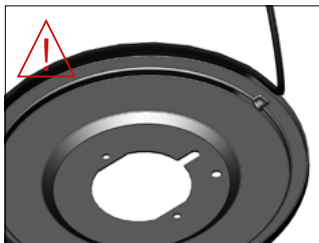

2. Carefully press the sealing ring over the edge of the heat shield. Check whether the ring is sealed completely and evenly.

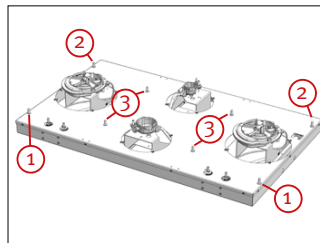

3. Overview of the mounting screws. These are separated into 3 groups and will come into play later in the instructions.

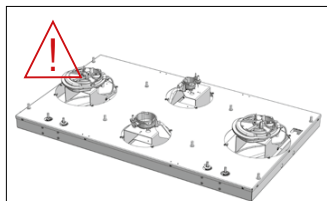

4. Unscrew all the mounting screws to approximately 3mm above the unit surface. Then put the heat diffuser in place on the unit.

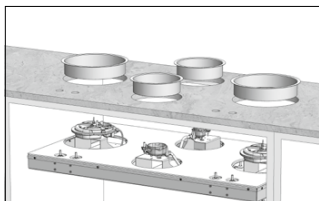

5. Place the flanges in the proper openings and carefully position the unit under the countertop. Check whether the heat diffuser is properly positioned.

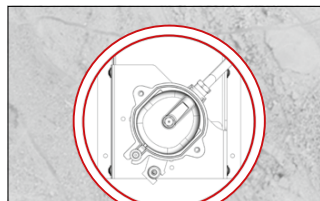

6. Check whether the flanges are centered in the cutouts. Attention: if they are not, then the flanges will not function properly.

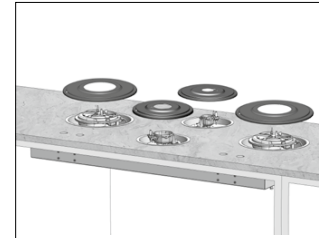

7. Position the heat shields, with the sealing rings in place (step 2), onto the burners and screw them into position with the screws provided.

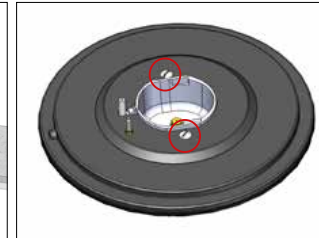

8. The heat shields of the 2kW and 3kW burners are secured with two screws and may only be secured in this manner.

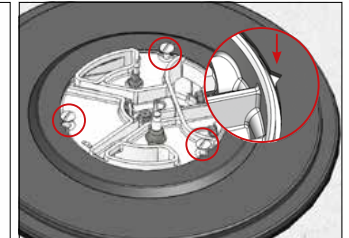

9. With the Simmer/Stir Fry burner make certain that the V-shaped opening is aligned with the axis of the burner. Fasten the heat shield with the three screws provided.

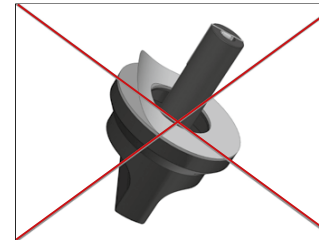

10. Attention: do not yet remove the adhesive strip at the bottom of the control knob mounting disc.

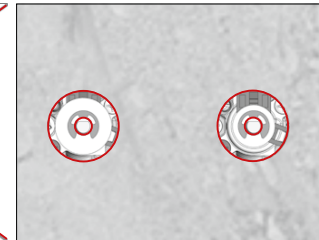

11. Carefully slide the unit into position: make sure that the burner gas valve stems are centered within the cutouts in the countertop.

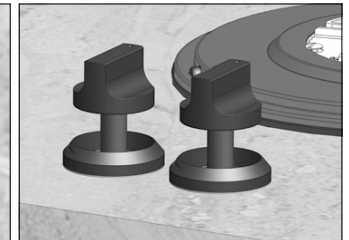

12. Press the control knobs firmly onto the valve stems with the markings directed towards the front. Depress the knob and check whether it springs back to the rest position.

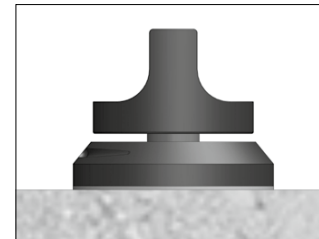

13. When properly placed there is a small space visible between the knob and upper end of the control knob mounting disc.

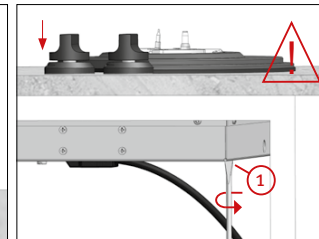

14. Tighten the mounting screws of group 1 (see step 3). This secures the heat diffuser against the countertop.

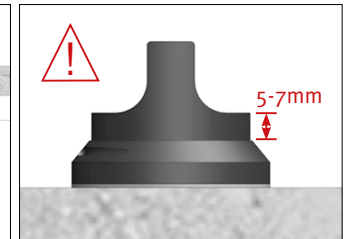

15. Stop tightening if the undersides of the control knobs descend towards the control knob mounting discs. The knobs must remain 5-7 mm above the mounting discs.

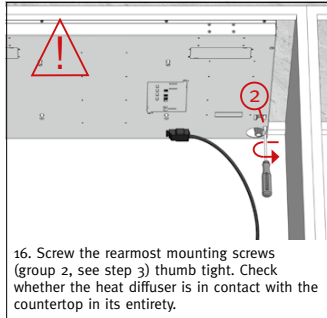

16. Screw the rearmost mounting screws (group 2, see step 3) thumb tight. Check whether the heat diffuser is in contact with the countertop in its entirety.

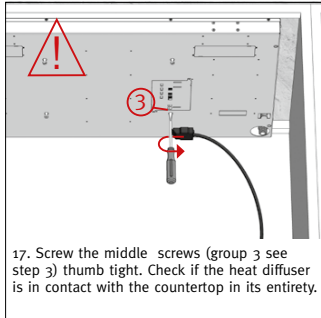

17. Screw the middle screws (group 3 see step 3) thumb tight. Check if the heat diffuser is in contact with the countertop in its entirety.

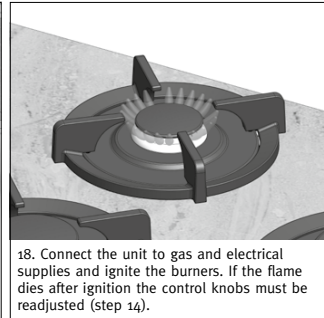

18. Connect the unit to gas and electrical supplies and ignite the burners. If the flame dies after ignition the control knobs must be readjusted (step 14).

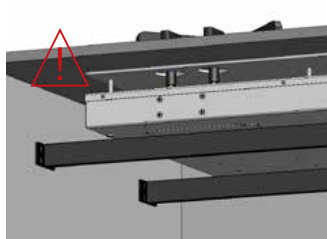

19. Check whether the heat diffuser is in entirely uninterrupted contact with the countertop and position the support bars in order to avoid stress to the countertop. See page 155.

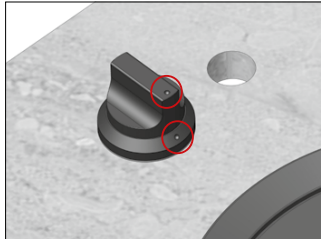

20. Remove the adhesive strip under the control knob mounting disc. Press the knob and disc as one unit onto the gas valve stem in such a way that they are centered and aligned.

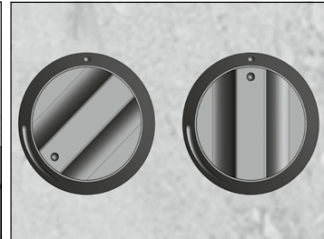

21. Check whether the knobs turn smoothly and that they spring back to the rest position after being depressed. If necessary, carefully remove the disc and then stick it down again.

Downloads



Installation

Installation of a Front Side module

Below you will find a step by step guide to the installation of a PITT cooking unit with Front Side controls.



In order to protect the guarantee and assure proper functioning of the cooking unit it is essential to follow and execute the installation guidelines precisely.



1. Overview of all parts.

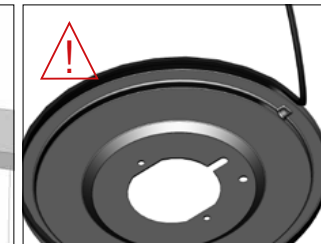

2. Carefully press the sealing ring over the edge of the heat shield. Check whether the ring is sealed completely and evenly.

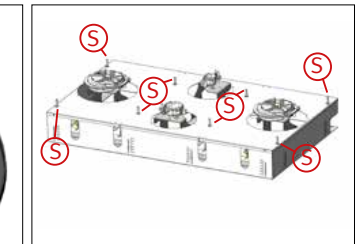

3. Overview of the mounting screws. These are separated into 3 groups and will come into play later in the instructions.

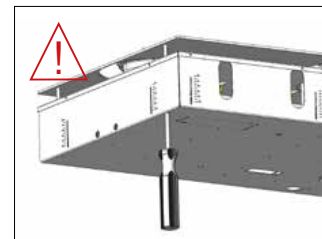

4. Turn back all the mounting screws to approximately 3mm above the unit surface. Then put the heat diffuser in place on the unit.

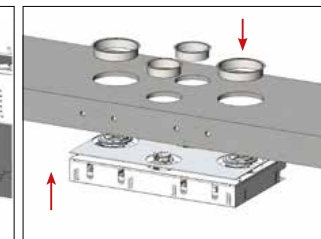

5. Place the flanges in the proper openings and carefully position the unit under the countertop. Check whether the heat diffuser is properly placed.

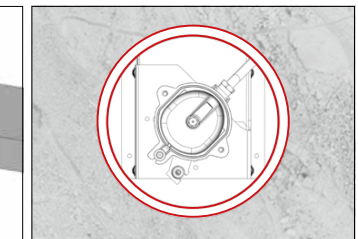

6. Check whether the flanges are centered in the cutouts. Attention: if this is not the case then the flanges will not function properly.

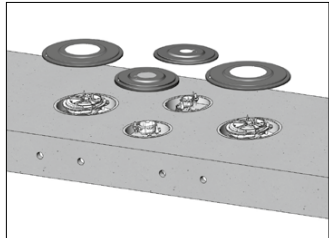

7. Position the heat shields, with the sealing rings in place (step 2), onto the burners and screw them into position with the screws provided.

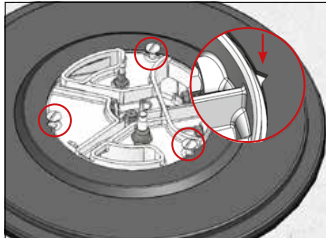

8. With the wok (stir fry) burner make certain that the V-shaped opening is aligned with the axis of the burner. Fasten the heat shield with the three screws provided.

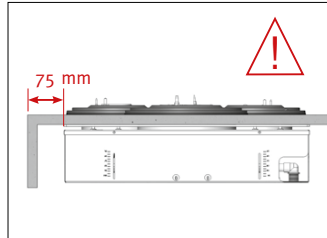

9. Measure the distance between the front of the unit and the countertop framing or uppermost front cabinet panel. This distance must be 75 mm.

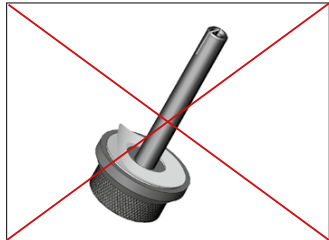

10. Attention: do not yet remove the adhesive strip at the bottom of the control knob mounting disc.

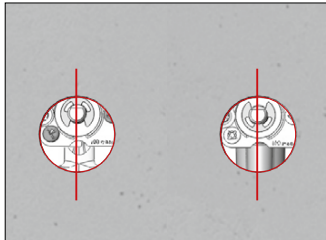

11. Carefully slide the unit into position: make sure that the valve stems are centered vertically within the cutouts in the countertop framing or cabinet panel.

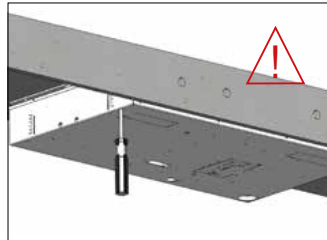

12. Tighten all the screws from back to front until the valve stems are centered in the cutouts. Check if all screws have been tightened.

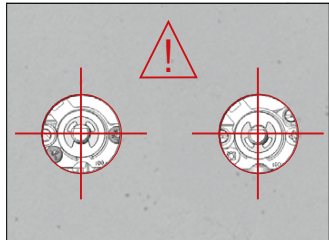

13. Correctly centered gas valve stems.

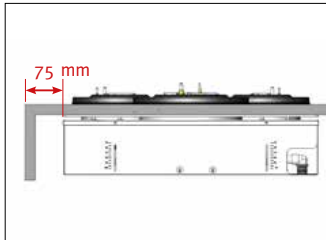

14. Recheck the measurement of the distance between the front side of the cooking unit and the countertop framing or upper front cabinet panel. This measurement must be 75 mm.



15. Remove the adhesive strip from the control knob mounting disc. Press the knob and mounting disc together as one unit over the gas valve stem in such a way that it is centered and aligned.

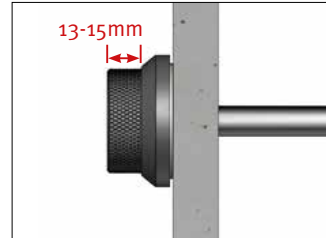

16. Check whether the control knob sticks out sufficiently. The knobs should extend 13-15 mm beyond the mounting discs.



17. Check whether the knobs turn smoothly and spring back after being depressed. If necessary, carefully remove the mounting disc and stick it down again.

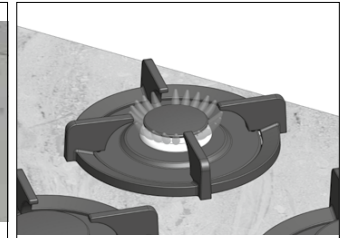

18. Connect the unit to gas and electrical supply and ignite the burners. In the event that the flames die after ignition the knobs must be readjusted (step 9).

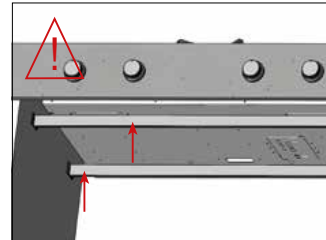

19. Support the unit with the double PITT cooking support bar set (see page 155).

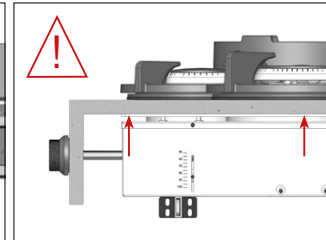

20. Check whether the heat diffuser is in uninterrupted contact with the counter top in its entirety.

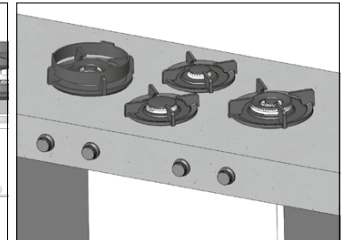

21. The unit is now ready for use.

— Downloads



Installation manual, Front Side

Installation

Installation of a support bar

Every PITT cooking module must be supported by the support bar package which consists of two support bars. These bars are provided with every module.

Equipment list:

- Retractable metal tape measure
- Philips screwdriver
- Hack saw



1. Determine the measurements of the cabinet and cut the support bar to size.
ATTENTION: The proper length of the support bar = the interior dimension of the cabinet minus 4 mm.

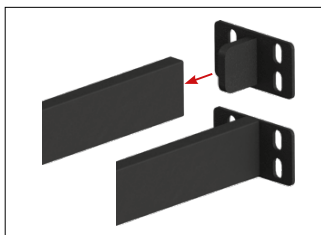

2. Place the mounting brackets onto the ends of the sawn to measure support bar.

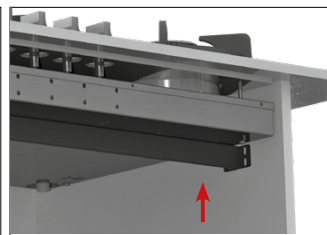

3. Put the support bar into the cabinet and position it against the underside of the PITT cooking unit.
BE CAREFUL WITH POSITIONING, SEE STEP 4!



4. Position the support bar in such a way that the mounting screws, gas connection and the electrical connections remain free and accessible.

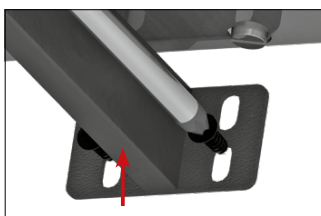

5. Push the support bar firmly against the underside of the PITT cooking unit and tighten the lower two screws thumb tight. Repeat this step for the other side of the cabinet.

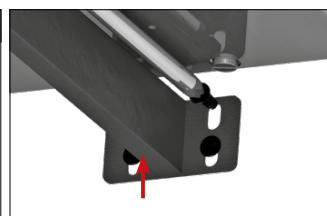

6. Push the support bar firmly against the underside of the PITT cooking unit and first tighten the upper two screws completely and then the lower screws.

150

Additional information

Changing orifices

Important

- Only the gas valves of the small (2kW) and medium (3kW) burner need to be reset when orifices are changed. These can be identified by the extra opening next to the gas valve.
- If the type of gas remains the same but the the pressure changes(e.g. , G20mbar to G20-13mbar) only the orifice needs to be changed.
- When making changes a new gas specification sticker must be placed over the existing sticker on the underside of the cooking unit.
- These guidelines are also downloadable via pittcooking.com/downloads.

– Supply list

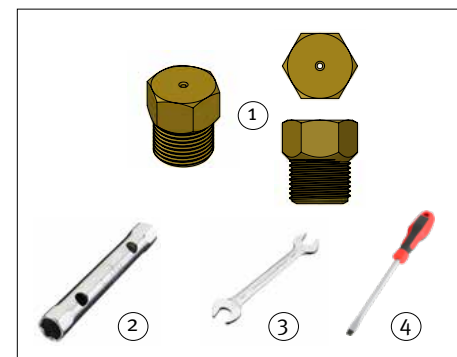

No.	Item
1	Orifices
2	7 mm pipe wrench

No.	Item
3	Socket wrench 7 mm
4	Flat head screwdriver

151

– Overview burners

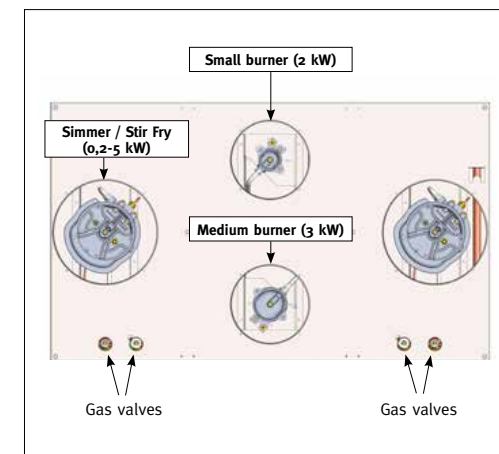

Changing orifices

– Small burner

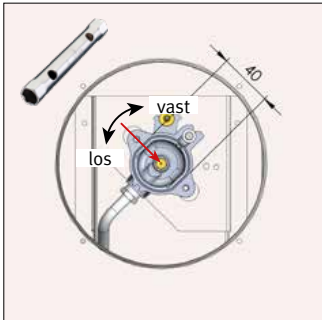

Changing of orifice small burner:
Loosen the existing orifice by turning counterclockwise. Install the new orifice by tightening clockwise.

– Medium burner

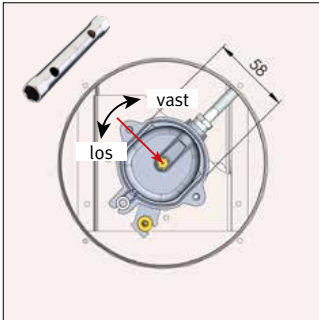

Changing of orifice medium burner:
Loosen the existing orifice by turning counterclockwise. Install the new orifice by tightening clockwise.

– Simmer/Stir Fry

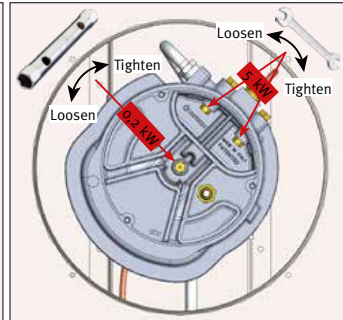

Changing of orifice Simmer/Stir Fry burner:
Loosen the existing orifice by turning counterclockwise. Install the new orifice by tightening clockwise.

– Natural Gas (NG, G20, G25) → LPG (LP, G30, G31)

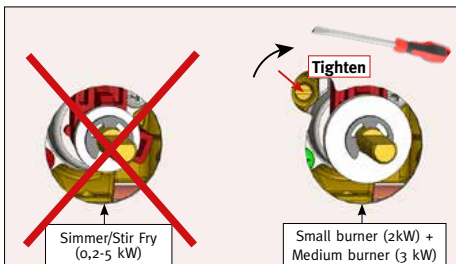

Completely tighten the mounting screw of the gas valve clockwise.

– LPG (LP, G30, G31) → Natural Gas (NG, G20, G25)

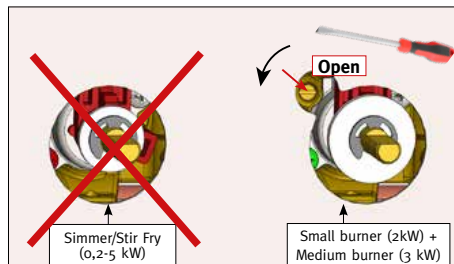

Open the mounting screw of the gas valve by 1/4 turn.

Certifications

– Certifications

The PITT cooking system is officially certified by the following organizations and/or seals of approval:

- CE (European Union)
- CSA (United States & Canada)
- SAI Global (Australia)
- CC-Gas (China)
- GOST-R (Russia)
- SPRING (Singapore/Asia)

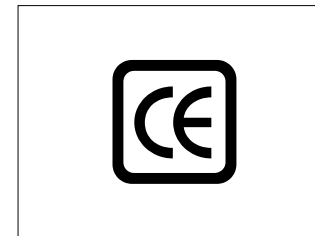

Ordering

– How to order models with Top Side controls

Send an email to salesorder@pittcooking.com with the following information about the order:

1. Name of model
2. Choice of burner material: Original, Professional or Black
3. Type of gas (default is G25/25 Natural Gas)
4. Reference

– How to order models with Front Side controls

Send an email to salesorder@pittcooking.com with the following information about the order:

1. All the correct measurements with help of the following form: “Template measurements - Front Side controls”. This form can be downloaded via the QR-code or via pittcooking.com/downloads.
2. Choice of burner material: Original, Professional or Black
3. Type of gas (default is G25/25 Natural Gas)



Delivery

- **Top Side models:** PITT cooking delivery time is normally 3 weeks from the time of placing an order.
- **Front Side models:** PITT cooking delivery time is normally 5-6 weeks from the time of placing an order.
- Different delivery times by prior agreement.

General conditions and guarantee

– General conditions



General conditions applicable to PITT cooking products are available via the QR-code, or via the website: pittcooking.com/terms-and-conditions (Dutch and English).

– Guarantee

- The terms of the guarantee are as follows:
 - a) 60 months for PITT products for household use, when the products are registered with PITT cooking as described below.
 - b) 6 months for PITT products used in a commercial setting.
 - c) Terms of guarantee are not applicable to PITT products installed outdoors.
- The term of the guarantee begins on the delivery date of the product stated on the purchase order.
- In order to validate the 60 month guarantee the buyer must register the product online at PITT cooking. The standard guarantee is for 24 months but by simply registering the product online, the consumer will enjoy an additional 36 months warranty at no charge.



Terms of Guarantee

You will find the terms of the guarantee via the QR code or on the website: pittcooking.com/downloads › Users › Guarantee.

Contact information

PITT Cooking America LLC
133 Amity St.
New York, NY 11201-6108
USA

— Communication

Phone: (720) 924-9948
General: info@pittcookingamerica.com
Sales: sales@pittcookingamerica.com
Service: service@pittcookingamerica.com

— Additional information

KvK: 30287993
VAT: NL820896809B01
HS-code: 7321 11

Downloads

Online documentation

The documents below can also be downloaded via our website:
www.pittcooking.com/downloads, section “For the dealer”.

Technical drawings per model

Technical drawings and cutout patterns specific to each model can be downloaded via the page for each model on our website. To access these, go to www.pittcooking.com/assortment. Then select the model desired.

— Design and preparation



— Technical drawings



— Cutout patterns



Downloads

— Front Side: Measurements



— Installation: Front Side



— Installation: Top Side



— Installation: Support bar



— General conditions & guarantee



— Changing orifices

